

PD Series Axial Piston Pumps

Variable Displacement

aerospace
climate control
electromechanical
filtration
fluid & gas handling
hydraulics
pneumatics
process control
sealing & shielding



ENGINEERING YOUR SUCCESS.

Contents	Page
General Information.....	1
Ordering Information.....	2
Technical Data.....	4
Control Options.....	5
Performance Data	
Pump Outlet Flow	12
Overall Efficiency	13
Shaft Input Power.....	14
Typical Noise Characteristics.....	16
Shaft Bearing Life	17
Dimensions	
P1060	18
P1075	22
P1100	26
P1140	30
Controls	35
Offer of Sale	43



WARNING – USER RESPONSIBILITY

FAILURE OR IMPROPER SELECTION OR IMPROPER USE OF THE PRODUCTS AND/OR SYSTEMS DESCRIBED HEREIN OR RELATED ITEMS CAN CAUSE DEATH, PERSONAL INJURY AND PROPERTY DAMAGE.

This document and other information from Parker-Hannifin Corporation, its subsidiaries and authorized distributors provide product or system options for further investigation by users having technical expertise.

The user, through its own analysis and testing, is solely responsible for making the final selection of the system and components and assuring that all performance, endurance, maintenance, safety and warning requirements of the application are met. The user must analyze all aspects of the application, follow applicable industry standards, and follow the information concerning the product in the current product catalog and in any other materials provided from Parker or its subsidiaries or authorized distributors.

To the extent that Parker or its subsidiaries or authorized distributors provide component or system options based upon data or specifications provided by the user, the user is responsible for determining that such data and specifications are suitable and sufficient for all applications and reasonably foreseeable uses of the components or systems.

Offer of Sale

Please contact your Parker representation for a detailed "Offer of Sale".

General Information

Description

- Variable displacement, axial piston pump for open-circuit applications
- Medium pressure, continuous operation at pressures up to 280 bar
- Low noise models for industrial markets
- Quiet and efficient control capability

Benefits

- Compact overall package size
- Quiet operation
- Low flow ripple to further reduce noise
- Elastomer seals that eliminate gaskets and external leakage
- High operating efficiency for lower power consumption and reduced heat generation
- Simple hydraulic controls with “no-leak” adjustments
- SAE and ISO standard mounting flanges and ports
- Long life, tapered-roller shaft bearings
- Long life, low friction, hydrostatically balanced swash plate saddle bearings
- Full power through-drive capability
- End or side inlet and outlet ports
- Case drain ports for horizontal or vertical, shaft-up mounting
- Optional minimum and maximum displacement adjustments
- Optional case-to-inlet check valve to extend shaft seal life
- Easy to service



Variable Displacement Piston Pumps Series PD

Ordering Information

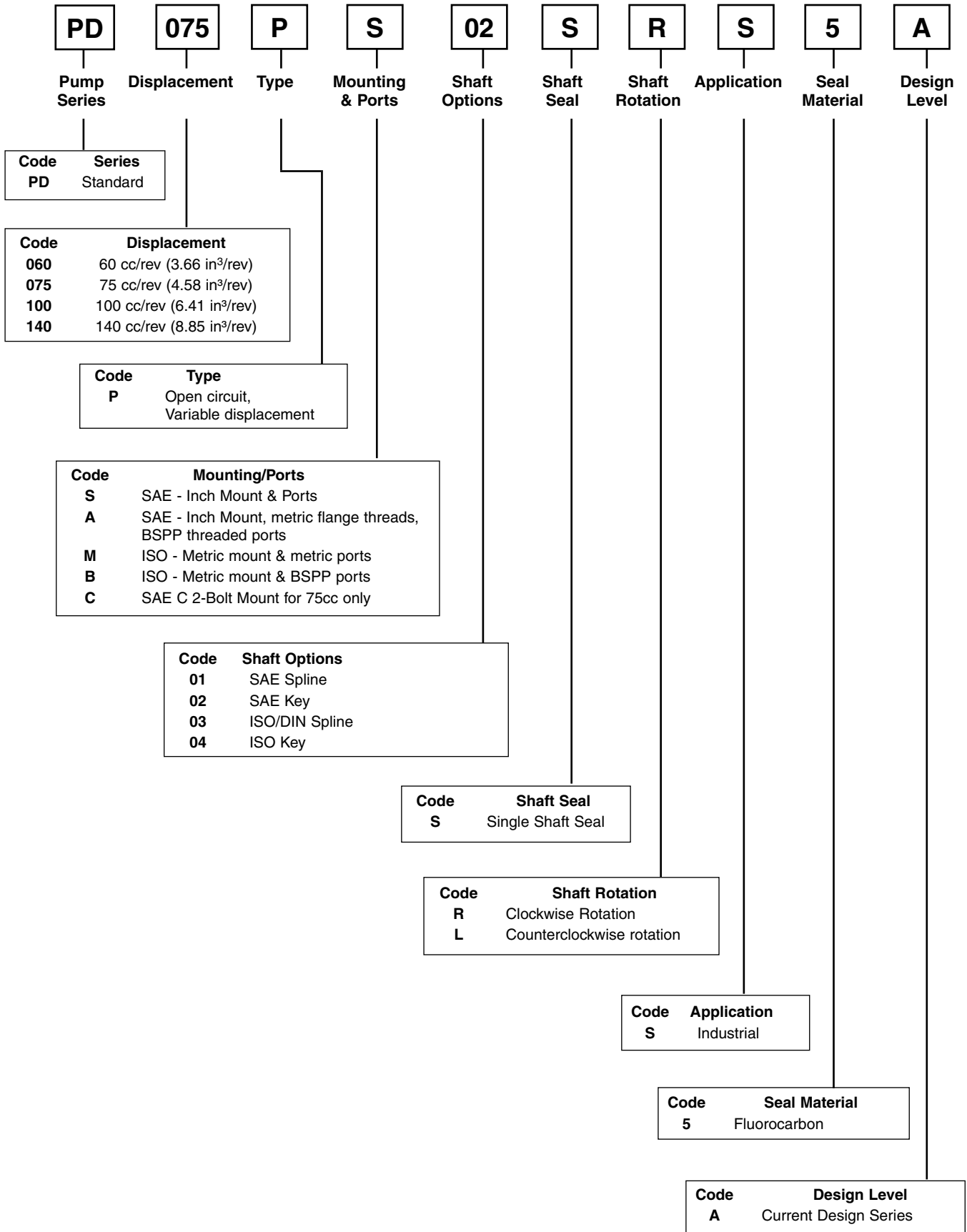

Ordering Information

Series PD

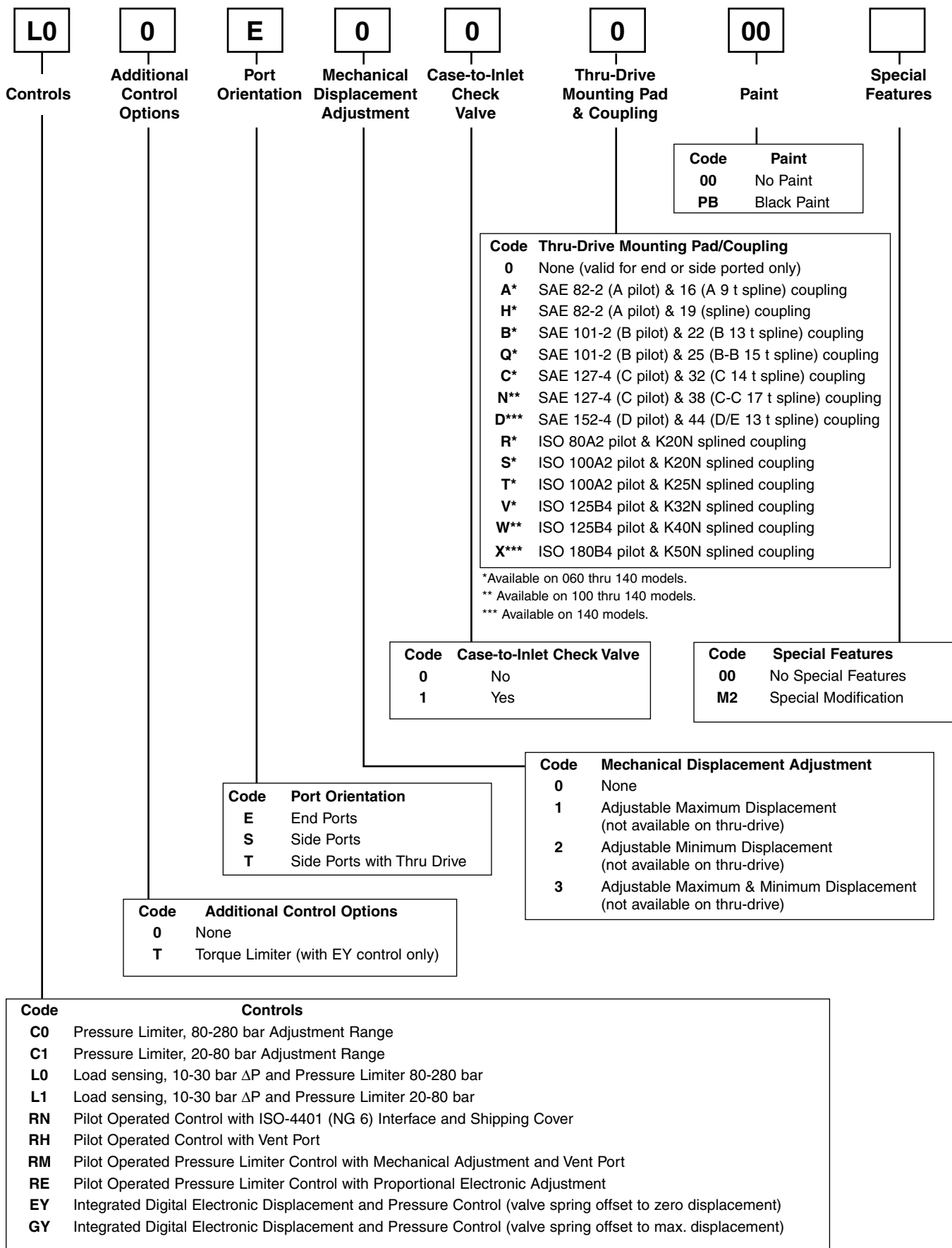

Technical Information

Technical Data

Model	PD060	PD075	PD100	PD140
Maximum Displacement, cm ³ /rev cu. in./rev	60 3.66	75 4.58	100 6.01	140 8.54
Outlet Pressure – Continuous, bar psi	280 4000			
Intermittent*, bar psi	320 4500			
Peak, bar psi	350 5000			
Maximum Speed (1.0 bar abs inlet), rpm	1800			
(0.8 bar abs inlet), rpm	1800	1800	1800	1500
Minimum Speed, rpm	600			
Inlet Pressure – Maximum, bar psi	10 145			
Rated, bar	1.0 absolute (0.0 gage)			
Minimum, bar	0.8 absolute (-0.2 gage)			
Case Pressure – Peak, bar	4.0 absolute (3.0 gage) and less than 0.5 bar above inlet pressure			
Rated, bar	2.0 absolute (1.0 gage) and less than 0.5 bar above inlet pressure			
Fluid Temperature Range, °C °F	-40 to +95 -40 to +203			
Fluid Viscosity – Rated, cSt	6 to 160			
Max. Intermittent, cSt	5000 (for cold starting)			
Min. Intermittent, cSt	5			
Fluid Contamination – Rated, ISO	20/18/14			
Maximum, ISO	21/19/16			
SAE Mounting – Flange, SAE	127-4 (C)		152-4 (D)	152-4 (D)
Key Shaft, SAE	32-1 (C)		38-1 (C-C)	44-1 (D)
Spline Shaft, SAE	14T-12/24P		17T-12/24P	13T-8/16P
Weight – End Port, kg lb	29 64	30 66	51 112	66 145
Side Port, kg lb	30 6	31 68	53 117	67 147
Thru-Drive, kg lb	34 75	35 77	55 121	82 180

*Intermittent pressure is defined as less than 10% of operation time, not exceeding 6 successive seconds.

Typical Control Reponse Times*

Control Description	Pump Operating Condition	Typical Control Response Time (ms)			
		060	075	100	140
"C" Pressure Limiter	Maximum Displacement to Zero	37	21	26	30
	Zero Displacement to Maximum	119	89	108	125
"L" Load Sensing	Maximum Displacement to Zero	54	40	43	45
	Zero Displacement to Maximum	186	97	189	280
"R" Pilot Operated Control	Maximum Displacement to Zero	43	37	39	40
	Zero Displacement to Maximum	125	115	123	130

* Based on NFPA testing standards

For max volume stops:

Pump Size	% Stroke reduction per turn
P*060	6.76
P*075	6.2
P*100	5.5
P*140	4.8

Control Adjustment Sensitivity:

- Load Sense 28 Bar/Turn
- Pressure Compensator 80 to 280 bar range (C0) = 40 Bar/Turn
- Pressure Compensator 20 to 80 bar range (C1) = 18.6 Bar/Turn



Control Option “C”
Pressure Limiter Control

The pressure limiter control is used to limit the maximum system pressure. The control acts such that full pump displacement is achieved unless the system valve restricts the output flow or the load pressure reaches the maximum setting of the control. If pump flow is restricted by the system valve, the pump will provide only the flow demanded, but at the maximum pressure setting of the compensator control. If the outlet flow is completely blocked, the pump will destroke to zero displacement and maintain the pressure at the setting of the compensator spring.

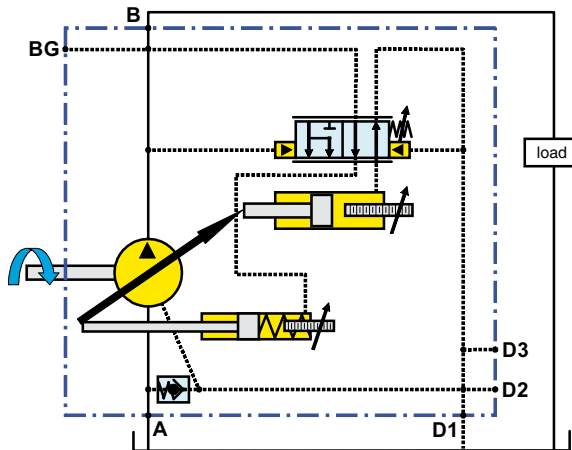
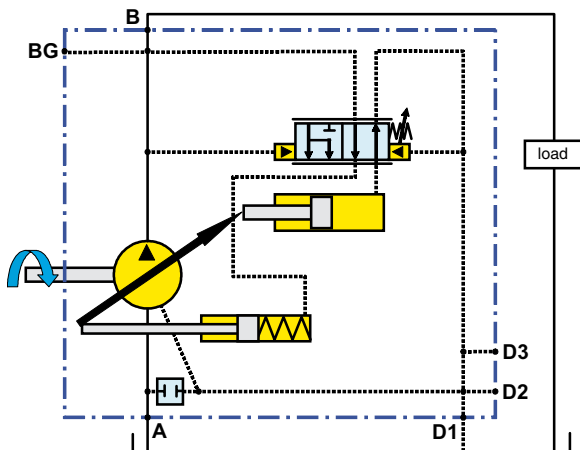
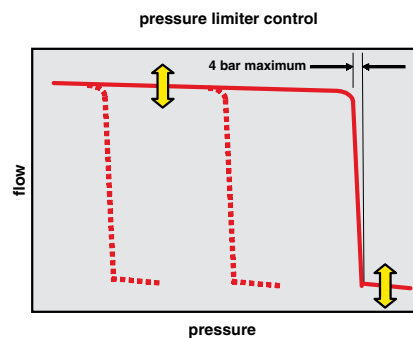
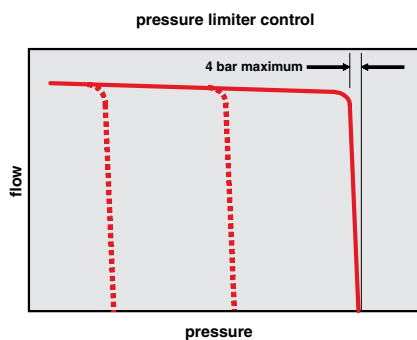

Pressure Limiter Control

**Pressure Limiter Control
with Optional Maximum & Minimum
Displacement Adjustments and
Case-to-Inlet Check Valve**

(A minimum displacement stop requires the use of a system relief valve.)

Refer to page 4 for typical control characteristics.

Technical Information

**Control Option “L”
Load Sensing and Pressure Limiter Control**

These controls feature load sensing and maximum pressure compensation. Load sense controls are used to match pump flow and pressure to system demands, thus minimizing losses due to wasted horsepower. The pump automatically adjusts for changes in drive speed and load pressures to match the pump output flow to the load requirement. Since the pump load sense control will maintain a constant pressure drop across the main system throttling valve, the flow rate will remain constant, independent of changes in load pressure and pump shaft speed.

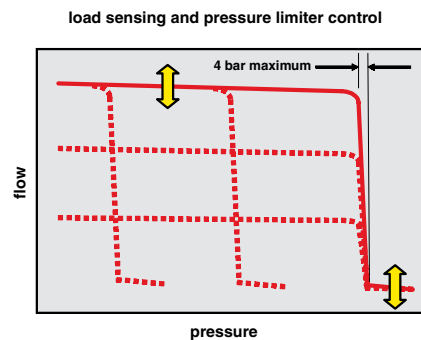
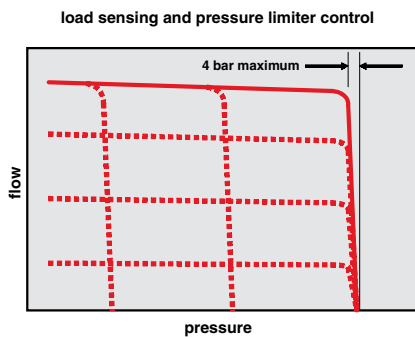

schematic diagram

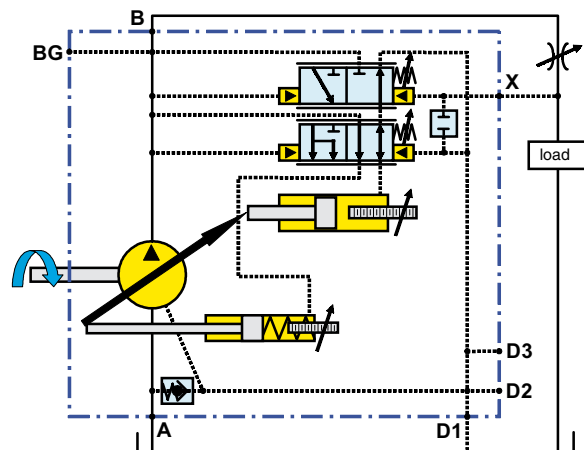
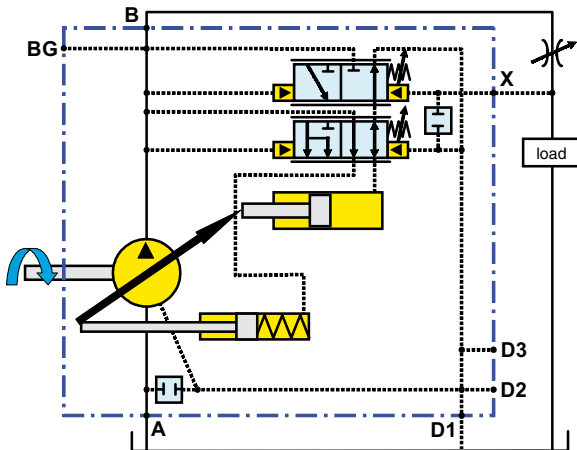

**Load Sensing and
Pressure Limiter Control**

**Load Sensing and
Pressure Limiter Control
with Optional Minimum & Maximum
Displacement Adjustments and
Case-to-Inlet Check Valve**

(A minimum displacement stop requires the use of a system relief valve.)

Refer to page 4 for typical control characteristics.

Control Options “RN”
Pilot Operated Control with ISO 4401
NG6 Interface

This control allows the pump pressure compensator setting to be adjusted from a remote relief valve. The control acts such that full pump displacement is achieved unless the system valve restricts the output flow or the load pressure reaches the maximum setting of the control. If pump flow is restricted by the system valve, the pump will provide only the flow demanded, but at the maximum pressure setting of the compensator control. If the outlet flow is completely blocked, the pump will destroke to zero displacement and maintain the pressure at the setting of the remote relief valve.

Note: Non-functioning control, provides ISO 4401 interface.

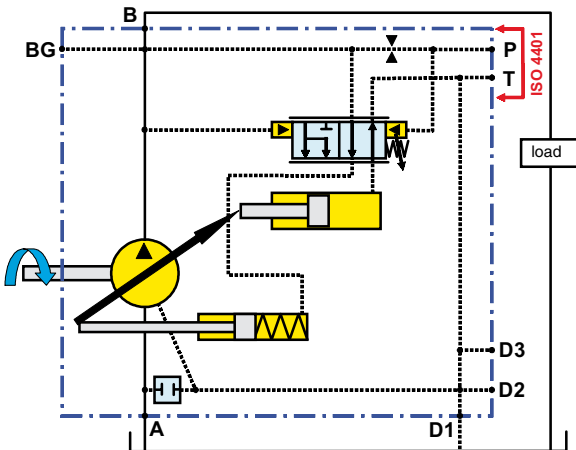
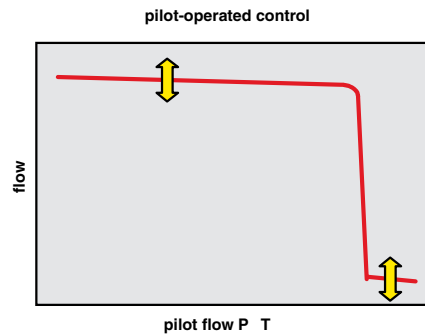
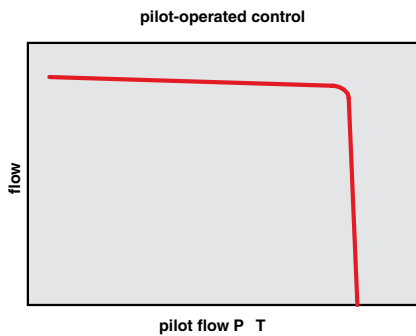

“RN”
Pilot Operated Control
with ISO 4401 NG6 Interface

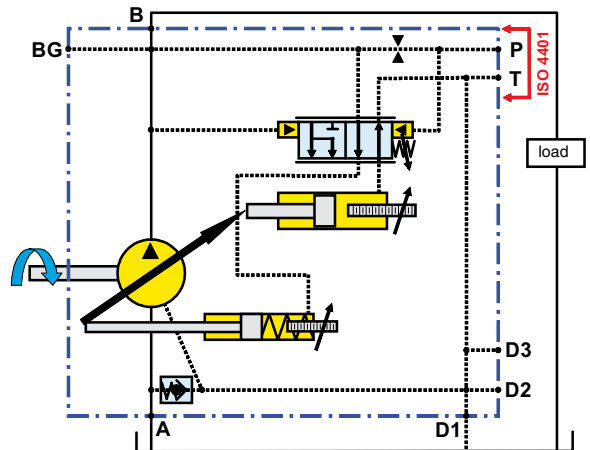

“RN”
with Optional Minimum & Maximum
Displacement Adjustments and
Case-to-Inlet Check Valve
 (A minimum displacement stop requires the use of a system relief valve.)

Refer to page 4 for typical control characteristics.

Technical Information

**Control Options “RH”
Pilot Operated Control
with Remote Control Port Z**

This control allows the pump pressure compensator setting to be adjusted from a remote relief valve. The control acts such that full pump displacement is achieved unless the system valve restricts the output flow or the load pressure reaches the maximum setting of the control. If pump flow is restricted by the system valve, the pump will provide only the flow demanded, but at the maximum pressure setting of the compensator control. If the outlet flow is completely blocked, the pump will destroke to zero displacement and maintain the pressure at the setting of the remote relief valve.

Note: If control port "Z" is plugged, the pump will remain fixed at maximum displacement and not compensate.

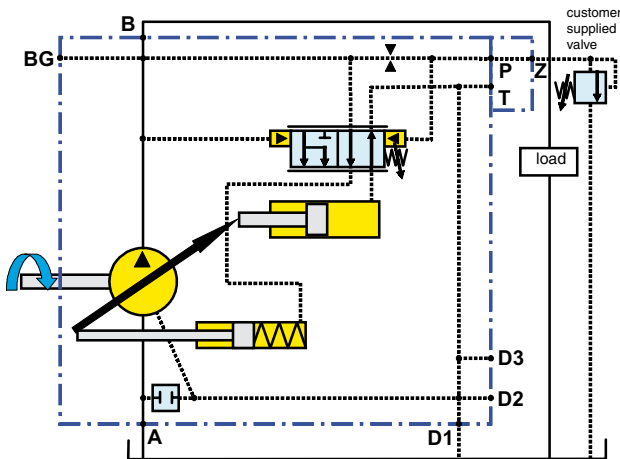
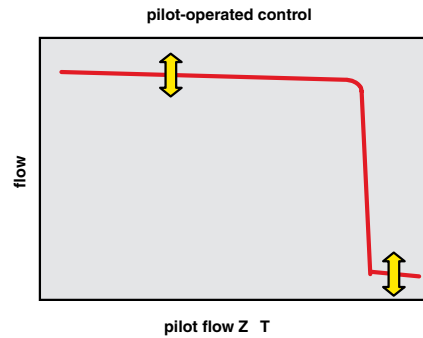
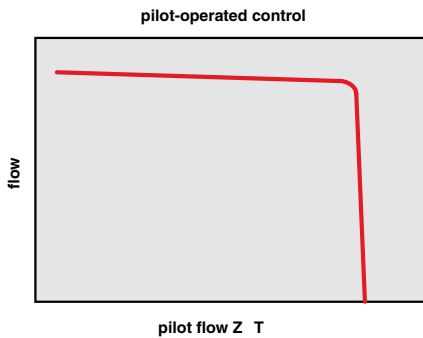

**“RH”
Pilot Operated**

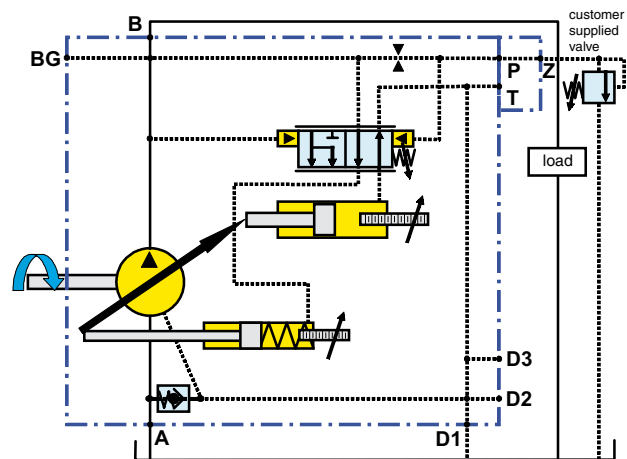

**“RH”
with Optional Minimum & Maximum
Displacement Adjustments and
Case-to-Inlet Check Valve**
(A minimum displacement stop requires
the use of a system relief valve.)

Refer to page 4 for typical control characteristics.

Control Options “RM”
Pilot Operated Pressure Limiter Control
with Vent Port V

This control allows the pump pressure compensator setting to be adjusted from a remote relief valve. The control acts such that full pump displacement is achieved unless the system valve restricts the output flow or the load pressure reaches the maximum setting of the control. If pump flow is restricted by the system valve, the pump will provide only the flow demanded, but at the maximum pressure setting of the compensator control. If the outlet flow is completely blocked, the pump will destroke to zero displacement and maintain the pressure at the setting of the remote relief valve.

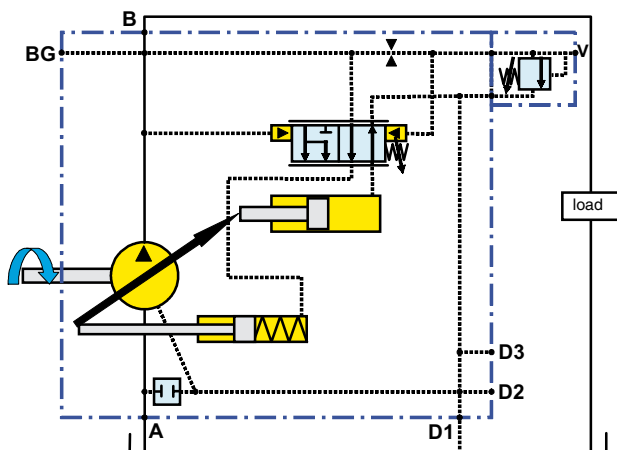
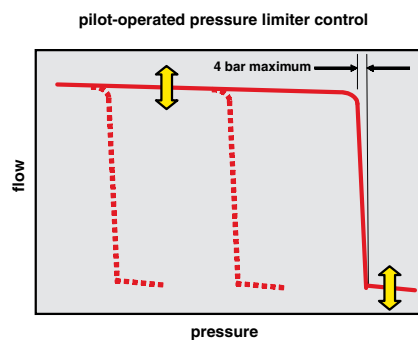
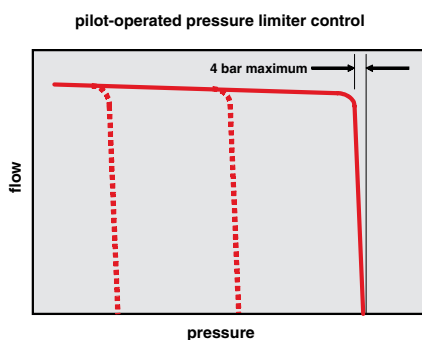

“RM”
Pilot Operated Pressure Control

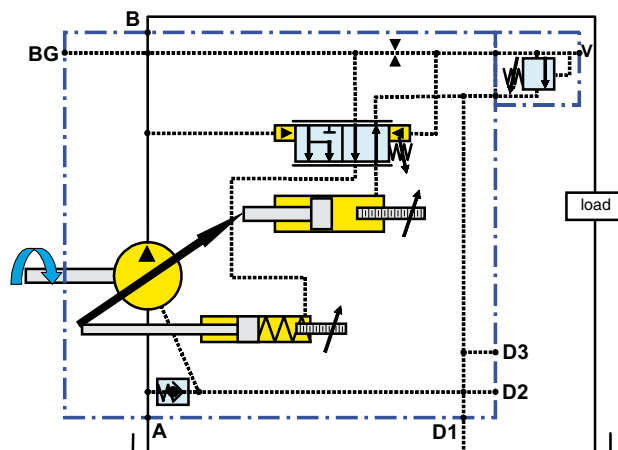

“RM”
with Optional Minimum & Maximum
Displacement Adjustments and
Case-to-Inlet Check Valve
 (A minimum displacement stop requires
 the use of a system relief valve.)

Refer to page 4 for typical control characteristics.

Control Options “RE”

Pilot Operated Pressure Limiter Control with Proportional Electronic Adjustment

This control allows the pump pressure compensator setting to be adjusted by an on-board 4VP01 proportional electronic remote relief valve. The control acts such that full pump displacement is achieved unless the system valve restricts the output flow or the load pressure reaches the maximum setting of the control. If pump flow is restricted by the system valve, the pump will provide only the flow demanded, but at the maximum pressure setting of the compensator control. If the outlet flow is completely blocked, the pump will destroke to zero displacement and maintain the pressure at the setting of the remote relief valve.

The information below is required for the RE control.

The following are recommended to drive the 4VP01 valve on the RE pump:

Parker Denison Part#	Description
701-00600-8	Proportional Amplifier
701-00007-8	Card Holder
701-00023-8	Power Supply
701-00066-8	Card Holder
701-00013-8	Potentiometer

Reference catalogs 3-EN2200-B and 9-EN601-A for setup.

pilot-operated pressure limiter control

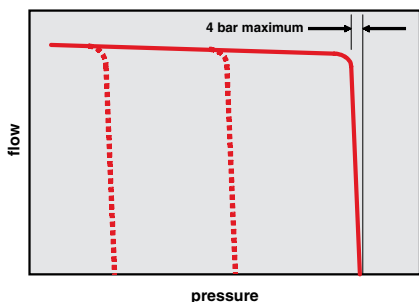

pressure

pilot-operated pressure limiter control

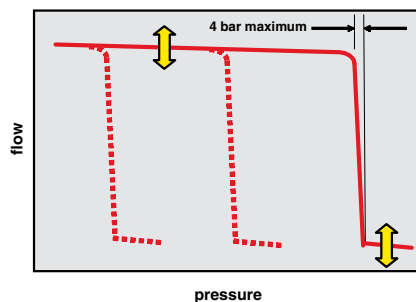

pressure

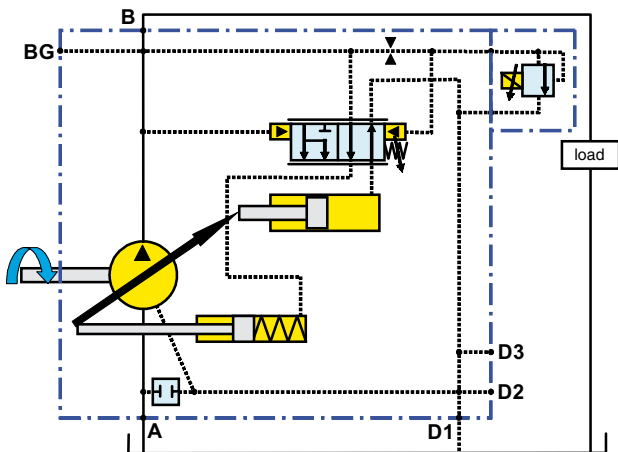

“RE”

Pilot Operated Pressure Limiter Control with Proportional Electronic Adjustment

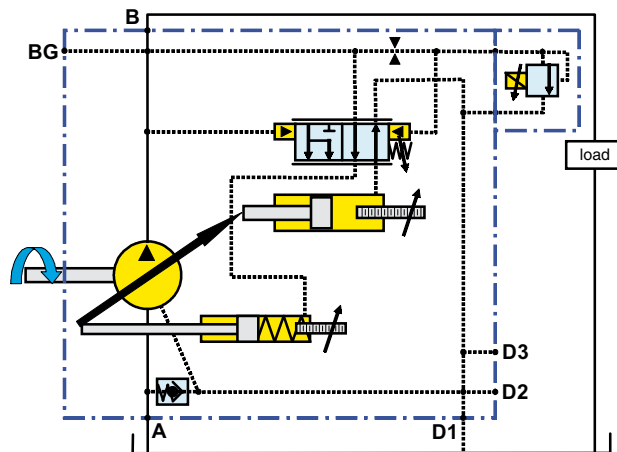

“RE”

with Optional Minimum & Maximum Displacement Adjustments and Case-to-Inlet Check Valve

(A minimum displacement stop requires the use of a system relief valve.)

Refer to page 4 for typical control characteristics.

**Control Options “EY” and “GY”
 Integrated Digital Electronic Control (IDEC)**

Available on the PD-075. This control will allow the user to select various control functions such as proportional pressure, proportional displacement and electronic torque limiting. All functions can be factory preset, analog driven or adjusted thru Windows-based software.

The control is integral to the pump and has no external wires or plumbing other than the signal wire which commands the flow and pressure output. The pump features internal sensors for pressure, speed and displacement, which are used with the control software to provide the desired pressure and flow output, even with varying parameters such as speed, temperature, viscosity and load pressure. The sensors also provide the user with hydraulic system monitoring capability for onboard diagnostics.

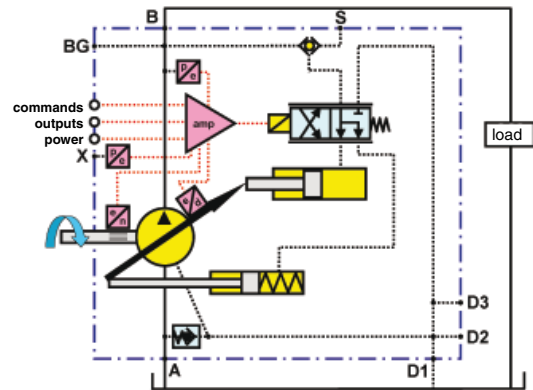

EY Option -(valve spring offset to zero displacement)

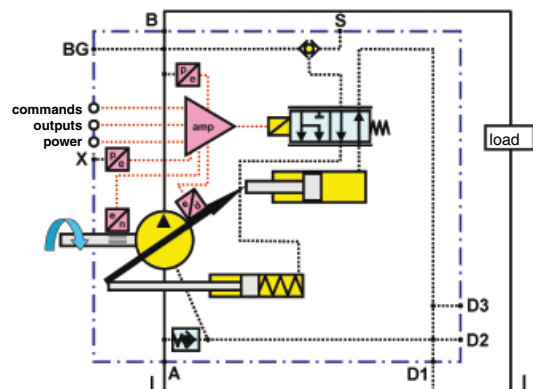

GY Option -(valve spring offset to max. displacement)

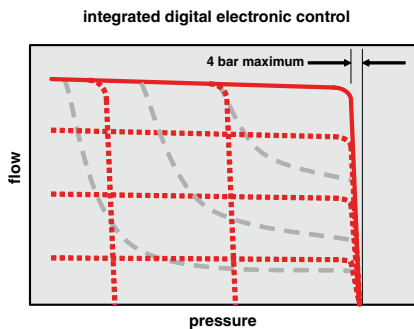

Description	Specifications	Comments
Power Supply Voltage	20 to 36 VDC	DC power supply (<5% ripple) (SAE J1455)
Power Supply Current	3.0 A maximum	1.8 A quiescent current
Input Connector	30 pin MS threaded connector	Mating connector provided by Parker
Onboard Power Supply	±5 VDC 10 mA maximum	Conditioned supply to power input command device
Input Commands	0 to 5 VDC or 4 to 20 mA or 0 to 20 mA	Displacement command, pressure limiter setting, torque limiter setting, load sense
Analog Output Signal	0 to 5 VDC 10 mA maximum	Actual operating pump displacement, outlet pressure, speed or signal pressure – PC user interface selects output signal parameter
"enable" digital input	20 to 36 VDC (supply voltage)	Input enables the operation of the pump control – remove this input to disable the pump control
"ready" digital output	0 or 5 VDC 5 mA maximum	Indicates the pump is ready for operation – control error exists if ready signal is not present
Ramp	0 to 90 seconds	PC user interface enables and sets the ramp
Hysteresis	<2% or maximum displacement	-
Repeatability	<1% of maximum displacement	-
Operating Temperature	-40 to +95°C	Pump inlet temperature
Serial Communication Port	RS-232	DB9 connector – Windows© PC connection to the user interface
EMI and RFI susceptibility	-	CE mark
Environmental Protection Class	IP67	-

PD Series Pump Outlet Flow

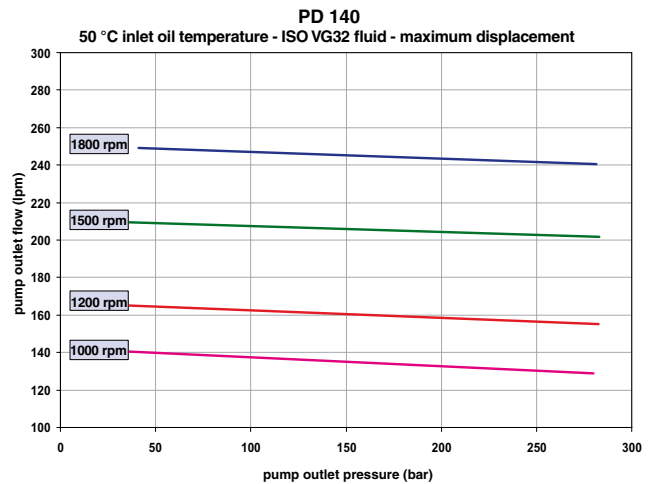
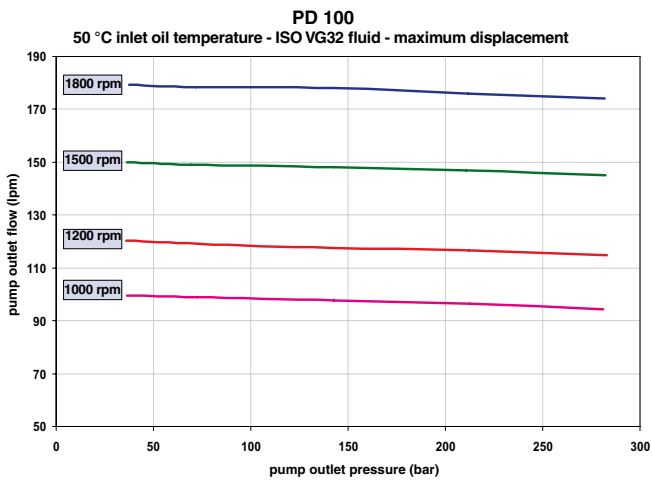
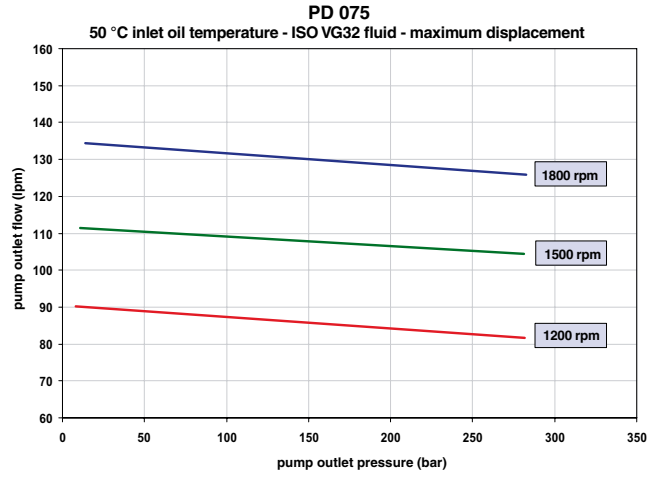
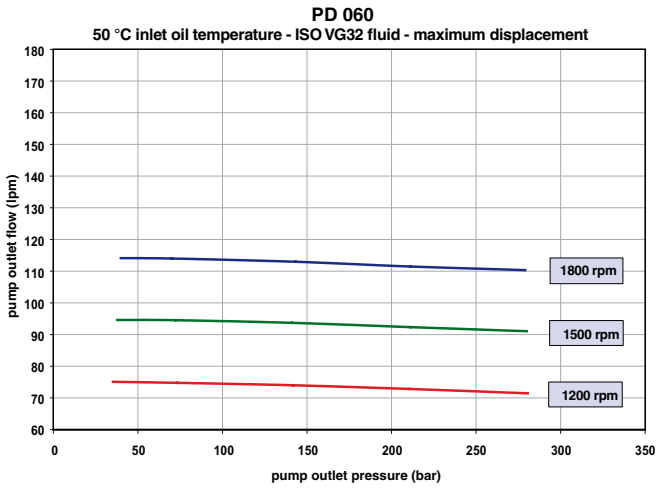

PD Series Overall Efficiency

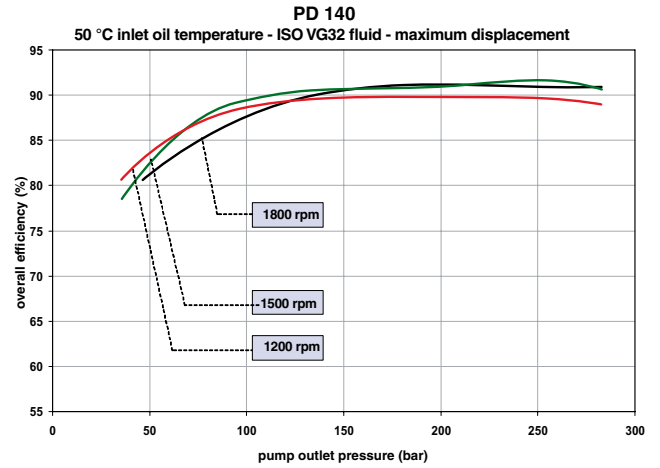
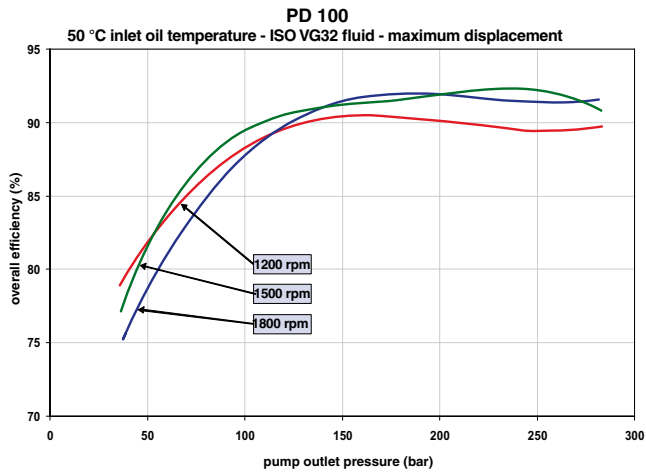
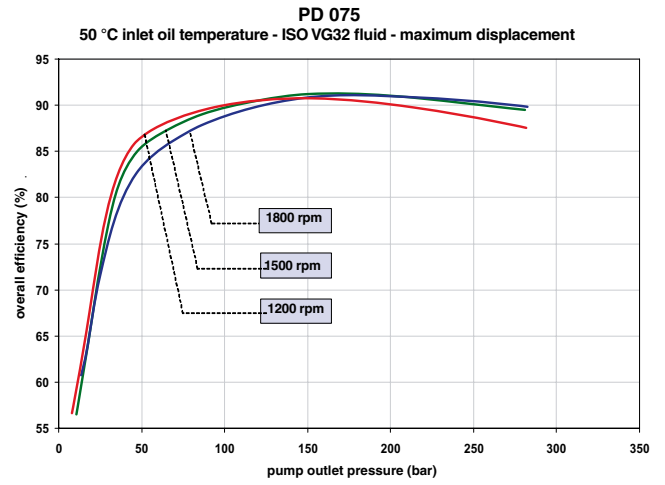
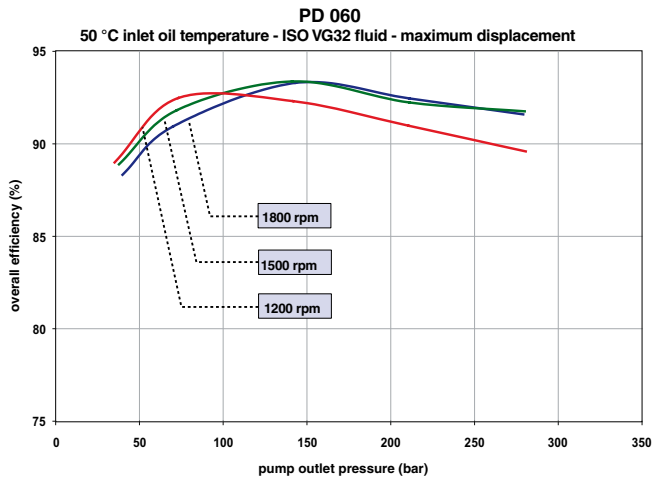

PD Series Shaft Input Power

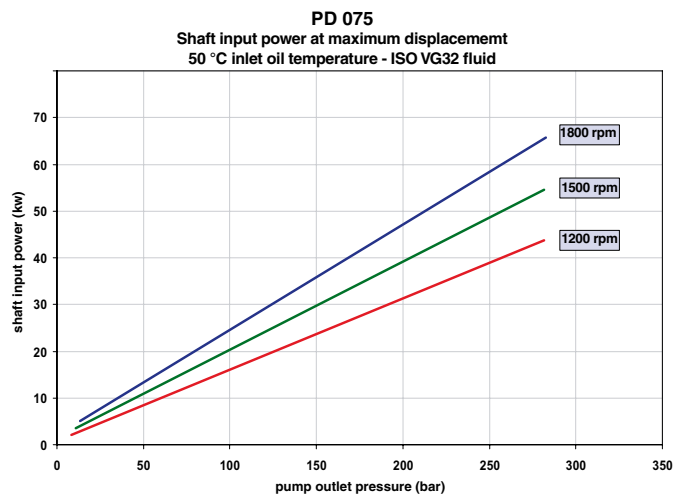
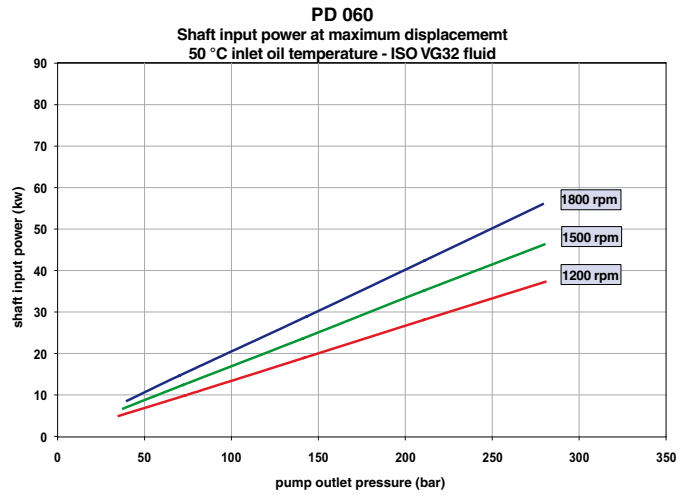
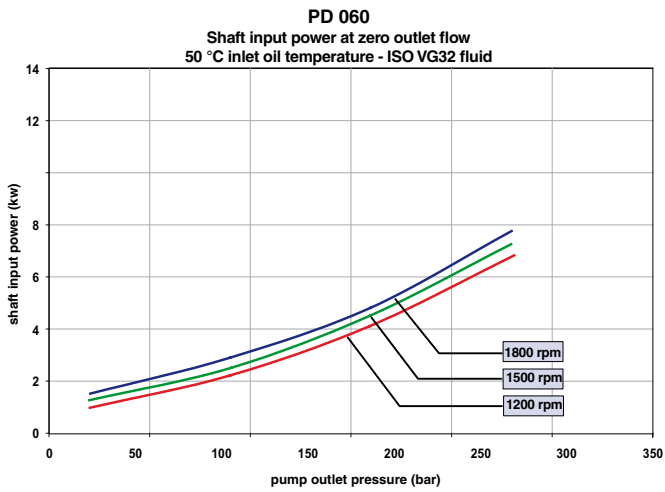

PD Series Shaft Input Power

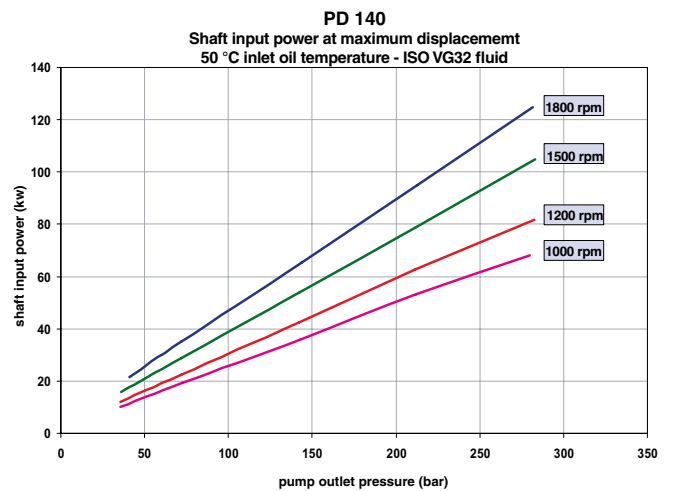
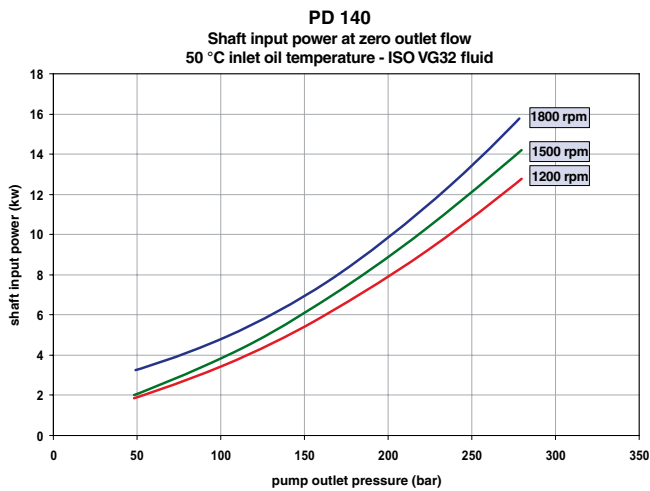
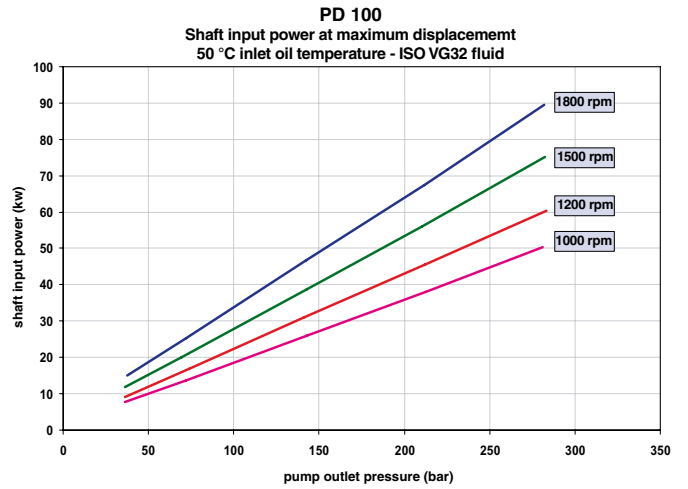
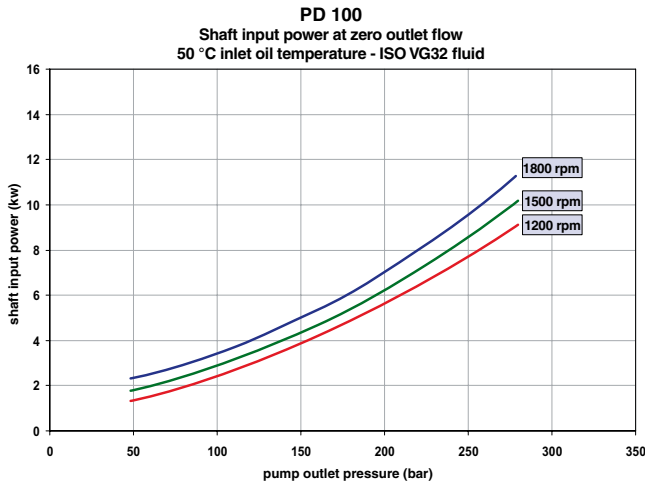

Performance Data

PD Series Typical Noise Characteristics

(These are anechoic sound pressure readings.)

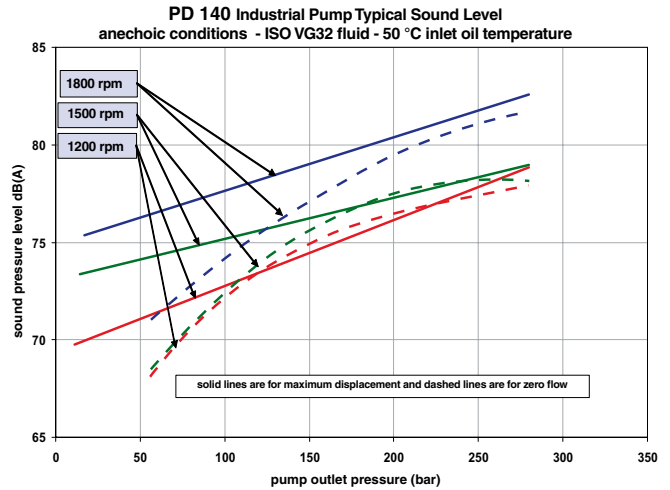
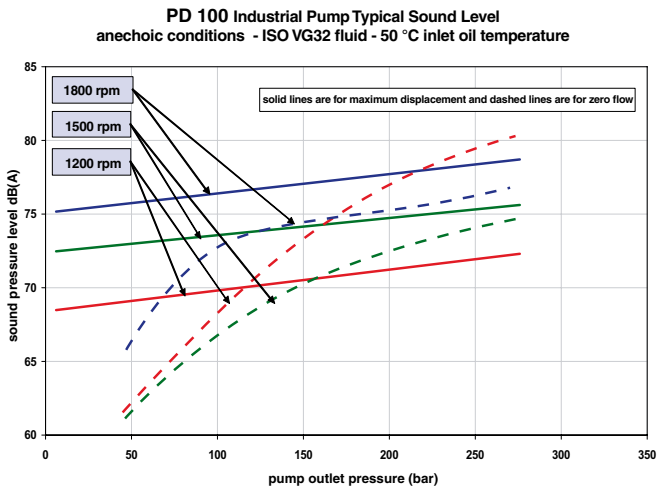
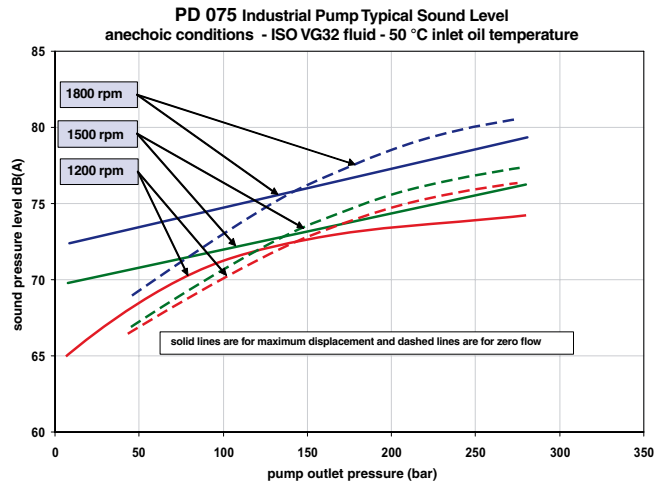
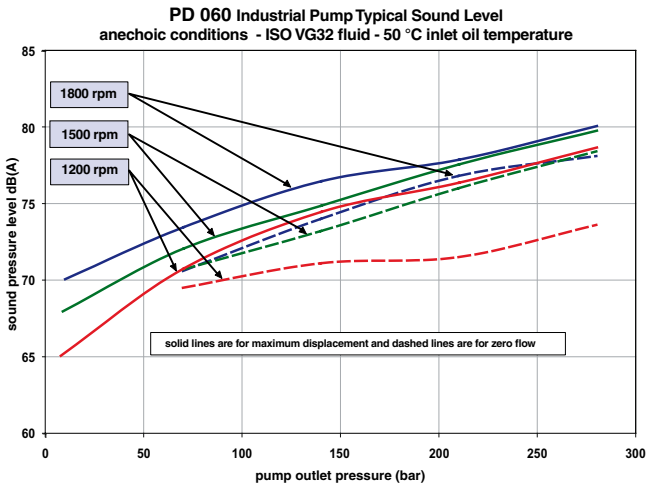

PD Series Shaft Bearing Life

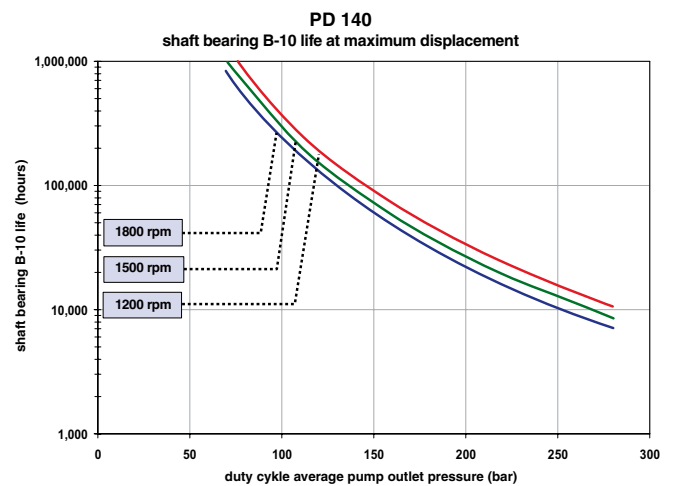
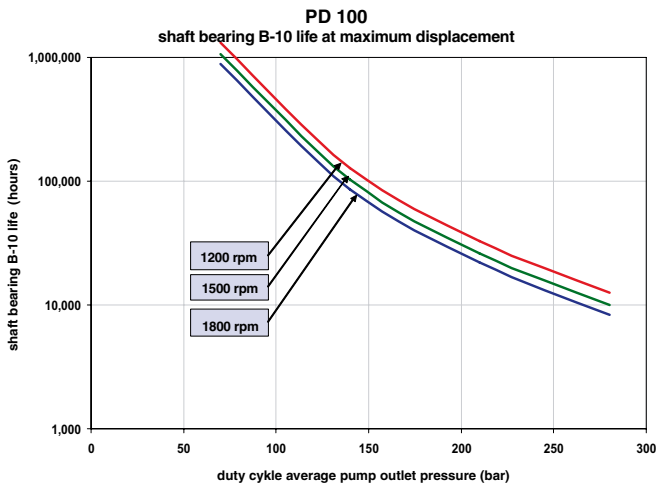
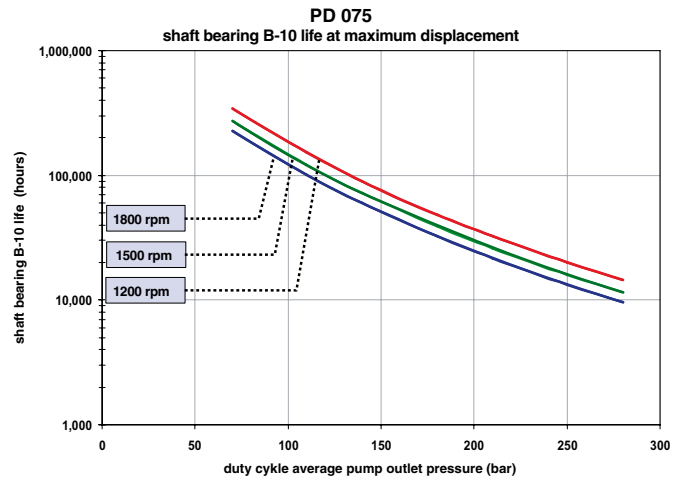
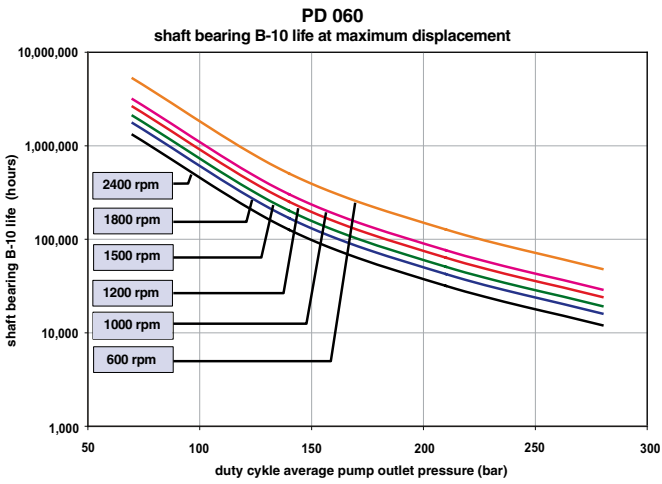

Dimensional Data

**Pump Installation - PD060
Input Shaft Dimensions**

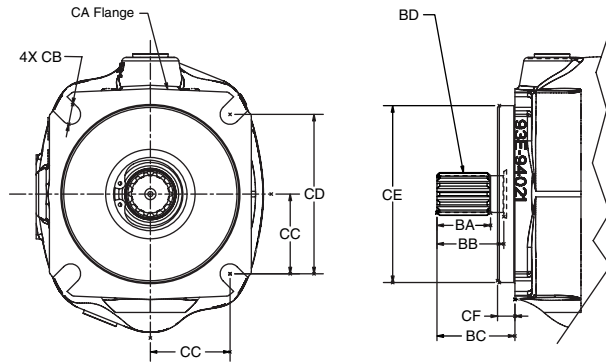
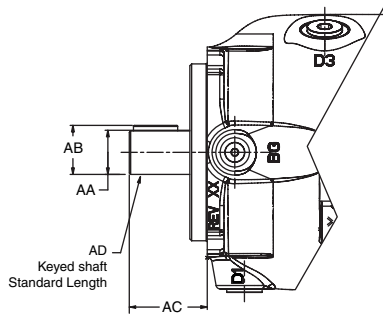

PD075	ISO	SAE
AA	32.021/32.002	31.75/31.70
AB	35.00/34.71	35.33/35.02
AC	68.8/67.2	56.8/55.2
AD	ISO E32N	SAE J744 32.1 C
BA	22.0	38.0
BB	36	48
BC	47.0/46.0	56.8/55.2
BD	SPLINE: ISO 3019/202991-P32N (REF DIN 5480) INVOLUTE SPLINE DATA FLAT ROOT SIDE FIT NUMBER OF TEETH - 14 MODULE - M2 PRESSURE ANGLE - 30 MAJOR DIAMETER - 32 TOOTH THICKNESS - 9e	SPLINE: SAE J744 SAE 32-4C INVOLUTE SPLINE DATA CLASS 2 FLAT ROOT SIDE FIT NUMBER OF TEETH - 14 PITCH - 12/24 PRESSURE ANGLE - 30 MAJOR DIAMETER - 1.2268 IN PITCH DIAMETER - 1.1666
CA	ISO 3019/202991 125B4SW	SAE J744 JUN96 127-4 C
CB	13.77/13.50	14.4 DIA.
CC	56.6	57.2
CD	113.2 SQUARE	114.5 SQUARE
CE	125.00/124.94 ISO 3019/2	127.00/126.95 SAE J744
CF	9.5/9.0	12.7/12.2

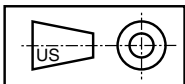

Pump Installation - PD060
End Port
“L” Control Option

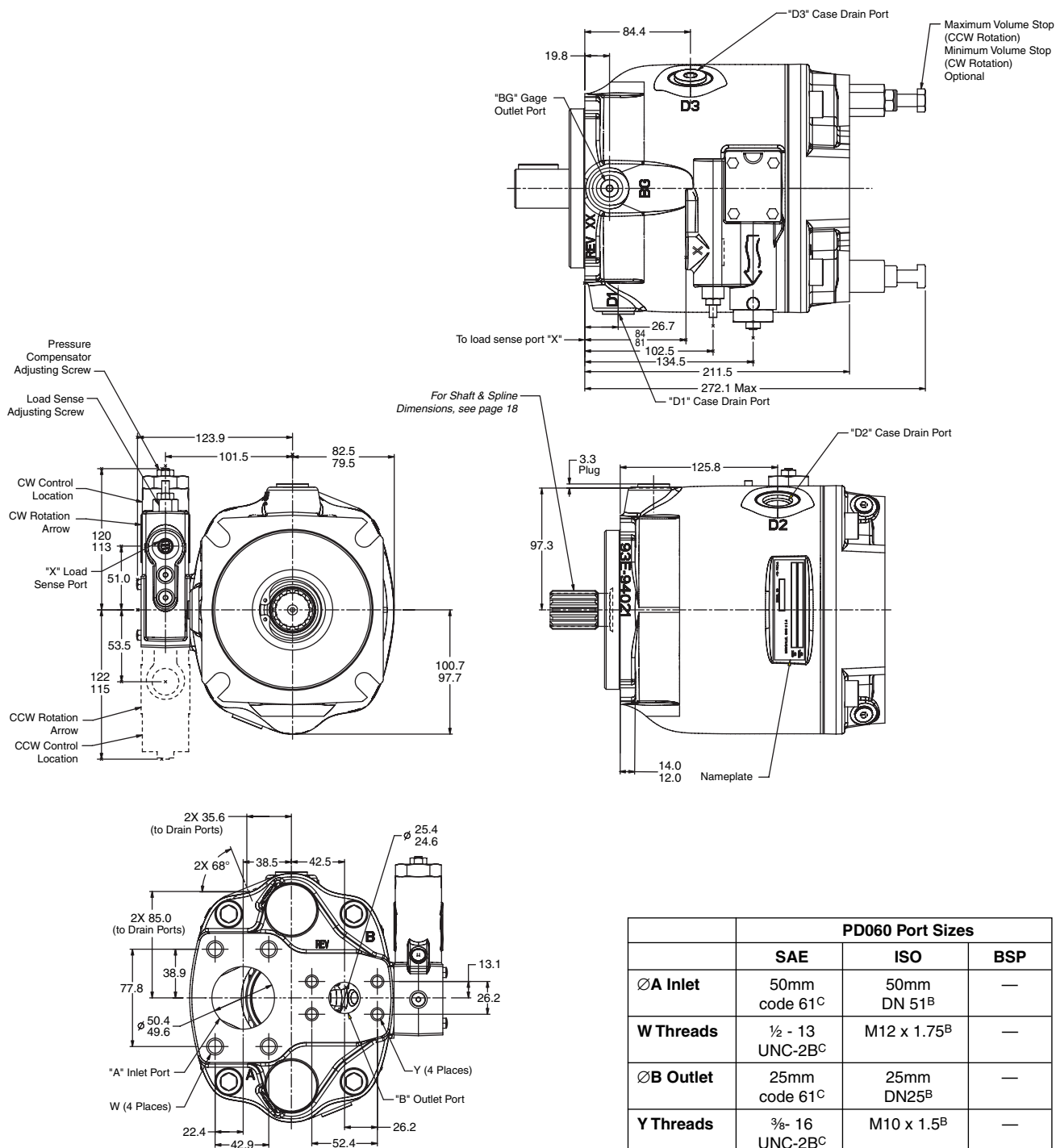

	PD060 Port Sizes		
	SAE	ISO	BSP
∅A Inlet	50mm code 61 ^C	50mm DN 51 ^B	—
W Threads	½ - 13 UNC-2B ^C	M12 x 1.75 ^B	—
∅B Outlet	25mm code 61 ^C	25mm DN25 ^B	—
Y Threads	¾ - 16 UNC-2B ^C	M10 x 1.5 ^B	—
BG	SAE-4 ^D	M12x1.5 ^A	¼" ^E
D1 D2 D3	SAE-10 ^D	M22x1.5 ^A	¾" ^E
X	SAE-4 ^D	M12x1.5 ^A	¼" ^E

Note A: Metric o-ring boss port conform to ISO 6149-1
 Note B: Metric 4-bolt flange port conforms to ISO 6162
 Note C: Inch 4-bolt flange port conforms to SAE J518
 Note D: Inch o-ring boss port conforms to SAE J514
 Note E: BSP boss port conforms to ISO 228-1

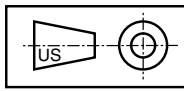

**Pump Installation - PD060
 Side Port
 "L" Control Option**

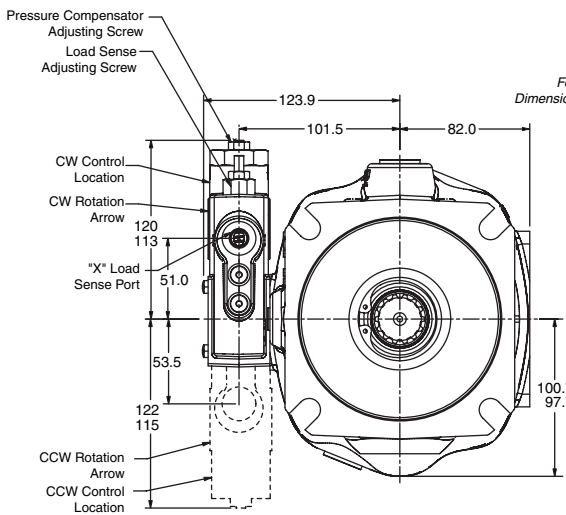
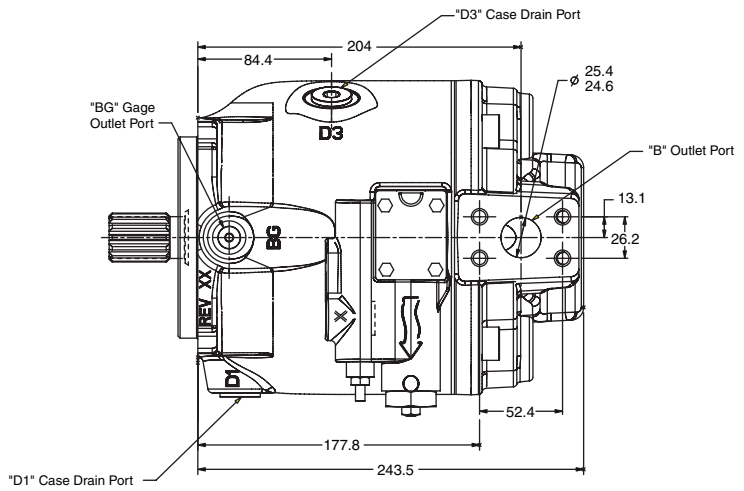

For Shaft & Spline
 Dimensions, see page 18

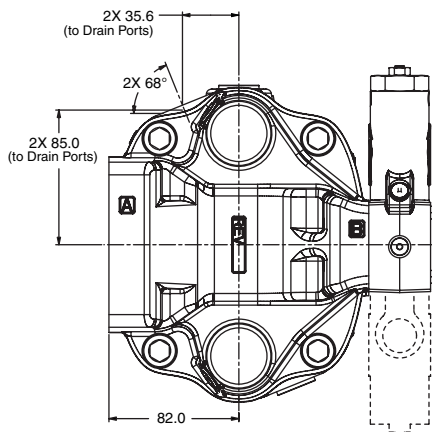
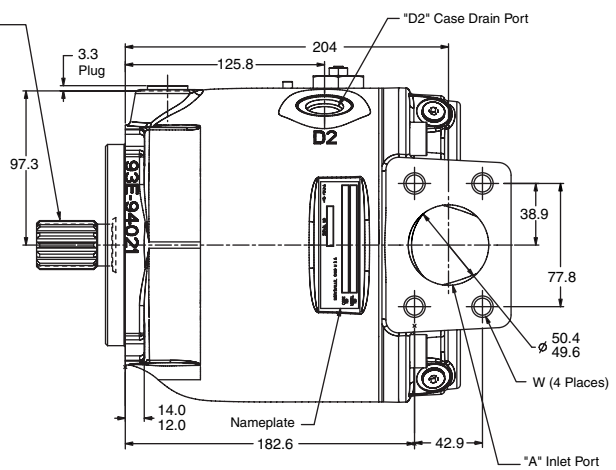

	PD060 Port Sizes		
	SAE	ISO	BSP
∅A Inlet	50mm code 61 ^C	50mm DN 51 ^B	—
W Threads	½ - 13 UNC-2B ^C	M12 x 1.75 ^B	—
∅B Outlet	25mm code 61 ^C	25mm DN25 ^B	—
Y Threads	¾ - 16 UNC-2B ^C	M10 x 1.5 ^B	—
BG	SAE-4 ^D	M12x1.5 ^A	¼" ^E
D1 D2 D3	SAE-10 ^D	M22x1.5 ^A	¾" ^E
X	SAE-4 ^D	M12x1.5 ^A	¼" ^E

Note A: Metric o-ring boss port conform to ISO 6149-1
 Note B: Metric 4-bolt flange port conforms to ISO 6162
 Note C: Inch 4-bolt flange port conforms to SAE J518
 Note D: Inch o-ring boss port conforms to SAE J514
 Note E: BSP boss port conforms to ISO 228-1

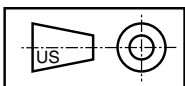

Pump Installation - PD060
Side Ports with Thru-Drive
“L” Control Option

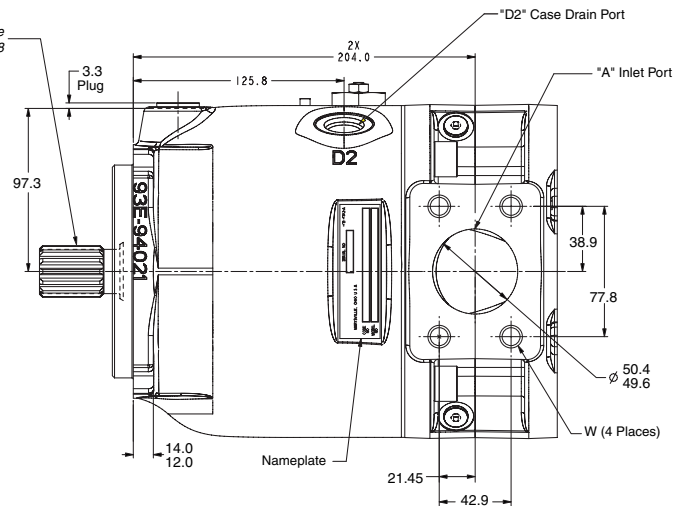
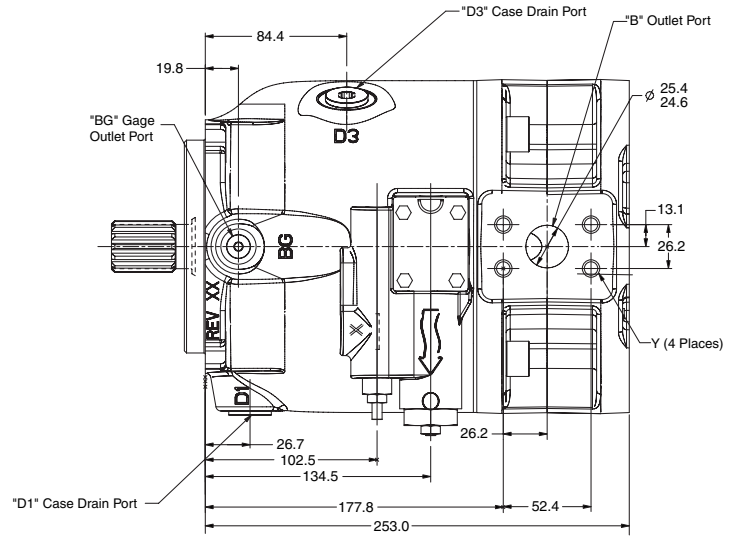
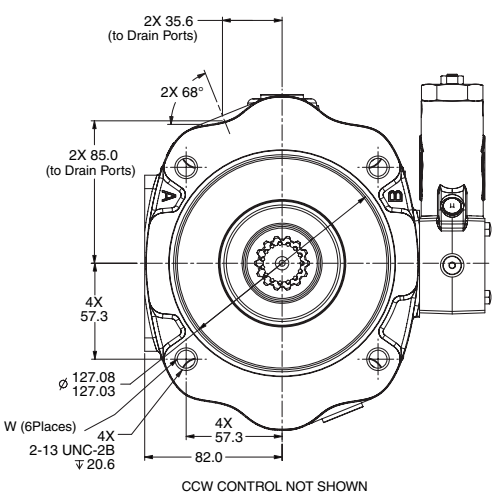
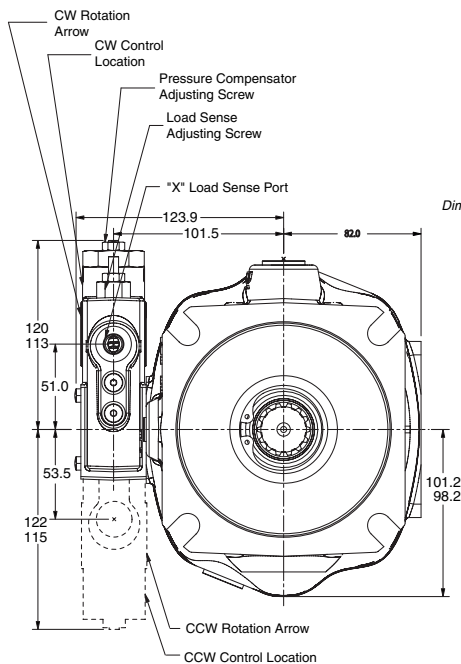

	PD060 Port Sizes		
	SAE	ISO	BSP
∅A Inlet	50mm code 61 ^C	50mm DN 51 ^B	—
W Threads	½ - 13 UNC-2B ^C	M12 x 1.75 ^B	—
∅B Outlet	25mm code 61 ^C	25mm DN25 ^B	—
Y Threads	¾ - 16 UNC-2B ^C	M10 x 1.5 ^B	—
BG	SAE-4 ^D	M12x1.5 ^A	¼" ^E
D1 D2 D3	SAE-10 ^D	M22x1.5 ^A	¾" ^E
X	SAE-4 ^D	M12x1.5 ^A	¼" ^E

Note A: Metric o-ring boss port conform to ISO 6149-1
 Note B: Metric 4-bolt flange port conforms to ISO 6162
 Note C: Inch 4-bolt flange port conforms to SAE J518
 Note D: Inch o-ring boss port conforms to SAE J514
 Note E: BSP boss port conforms to ISO 228-1

Shaft Location	PD060 Shaft Size & Type	Shaft Torque Capacity (Nm)
Input End	SAE C 32-1 Key	562
	SAE C 14T Spline	732
	ISO E32N Key	576
	ISO 14T Spline	732
Thru-Drive End	Spline Coupling	366

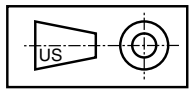

Dimensional Data

**Pump Installation - PD075
Input Shaft Dimensions**

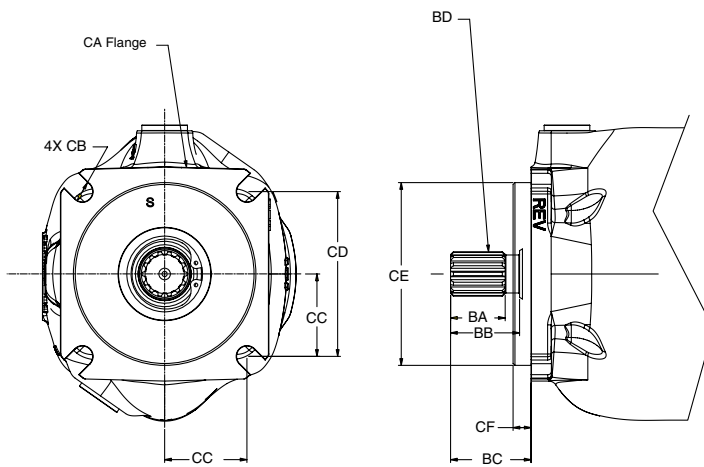
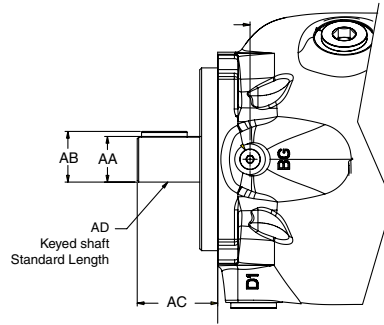

PD075	ISO	SAE
AA	32.021/32.002	31.75/31.70
AB	35.00/34.71	35.33/35.02
AC	68.8/67.2	56.8/55.2
AD	ISO E32N	SAE J744 32.1 C
BA	22.0	38.0
BB	36	48
BC	47.0/46.0	56.8/55.2
BD	SPLINE: ISO 3019/202991-P32N (REF DIN 5480) INVOLUTE SPLINE DATA FLAT ROOT SIDE FIT NUMBER OF TEETH - 14 MODULE - M2 PRESSURE ANGLE - 30 MAJOR DIAMETER - 32 TOOTH THICKNESS - 9e	SPLINE: SAE J744 SAE 32-4C INVOLUTE SPLINE DATA CLASS 2 FLAT ROOT SIDE FIT NUMBER OF TEETH - 14 PITCH - 12/24 PRESSURE ANGLE - 30 MAJOR DIAMETER - 1.2268 IN PITCH DIAMETER - 1.1666
CA	ISO 3019/202991 125B4SW	SAE J744 JUN96 127-4 C
CB	13.77/13.50	14.4 DIA.
CC	56.6	57.2
CD	113.2 SQUARE	114.5 SQUARE
CE	125.00/124.94 ISO 3019/2	127.00/126.95 SAE J744
CF	9.5/9.0	12.7/12.2

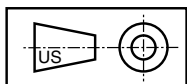

**Pump Installation - PD075
 End Port
 "L" Control Option**

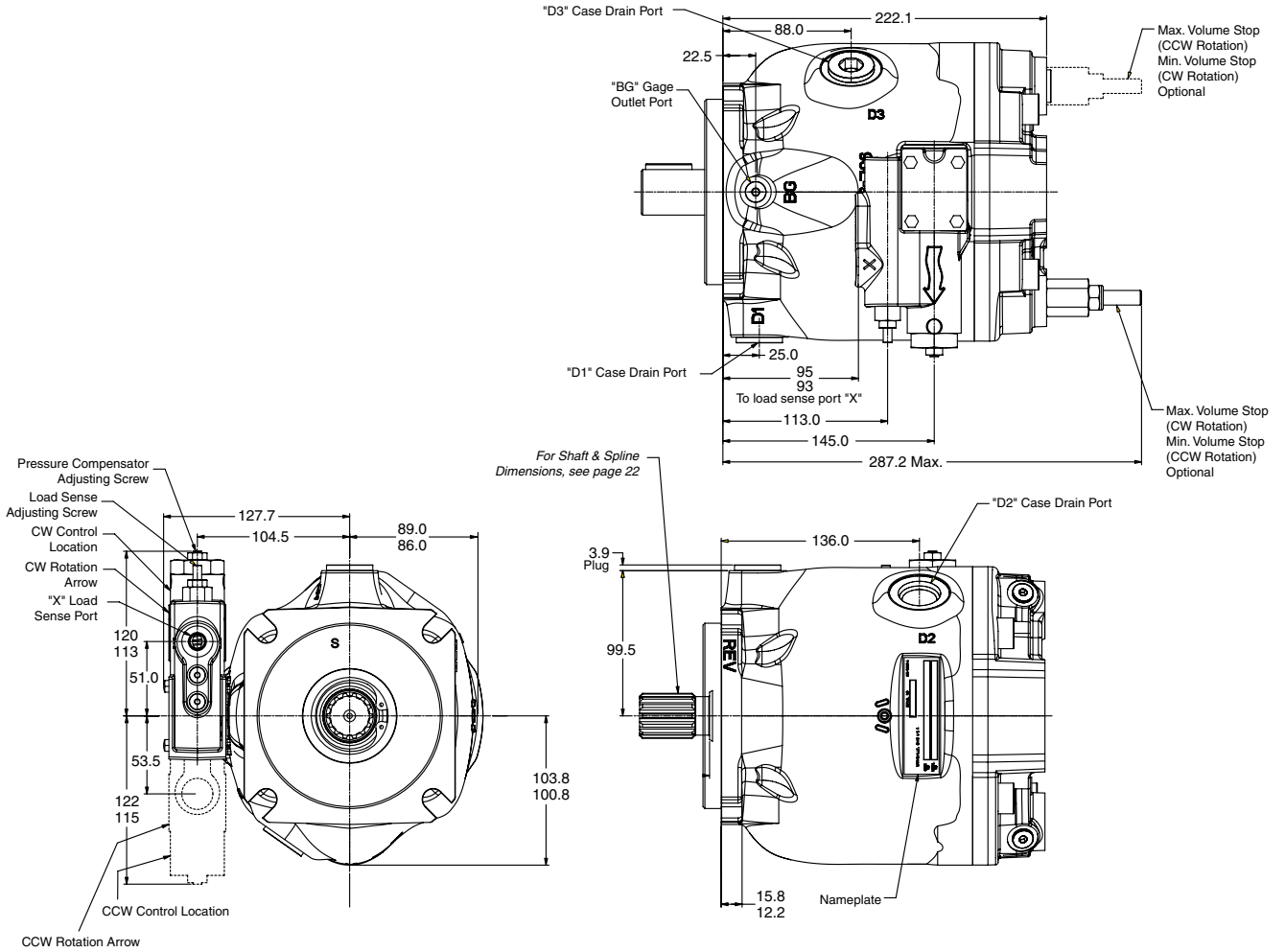

	PD075 Port Sizes		
	SAE	ISO	BSP
∅A Inlet	50mm code 61 ^C	50mm DN 51 ^B	—
W Threads	½ - 13 UNC-2B ^C	M12 x 1.75 ^B	—
∅B Outlet	25mm code 61 ^C	25mm DN25 ^B	—
Y Threads	¾ - 16 UNC-2B ^C	M10 x 1.5 ^B	—
BG	SAE-4 ^D	M12x1.5 ^A	¼" ^E
D1 D2 D3	SAE-12 ^D	M27x2 ^A	¾" ^E
X	SAE-4 ^D	M12x1.5 ^A	¼" ^E

Note A: Metric o-ring boss port conform to ISO 6149-1
 Note B: Metric 4-bolt flange port conforms to ISO 6162
 Note C: Inch 4-bolt flange port conforms to SAE J518
 Note D: Inch o-ring boss port conforms to SAE J514
 Note E: BSP boss port conforms to ISO 228-1

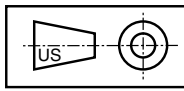

**Pump Installation - PD075
 Side Port
 "L" Control Option**

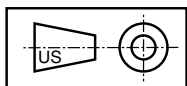
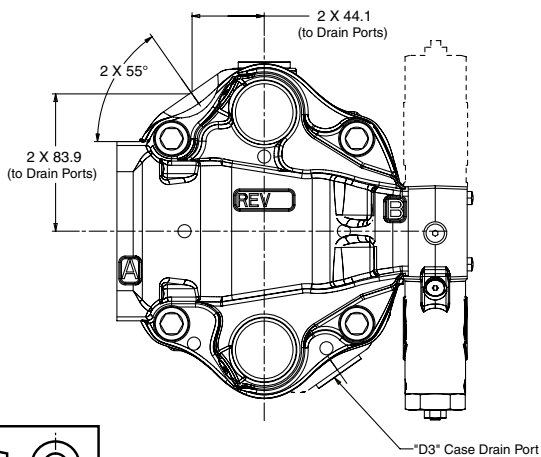
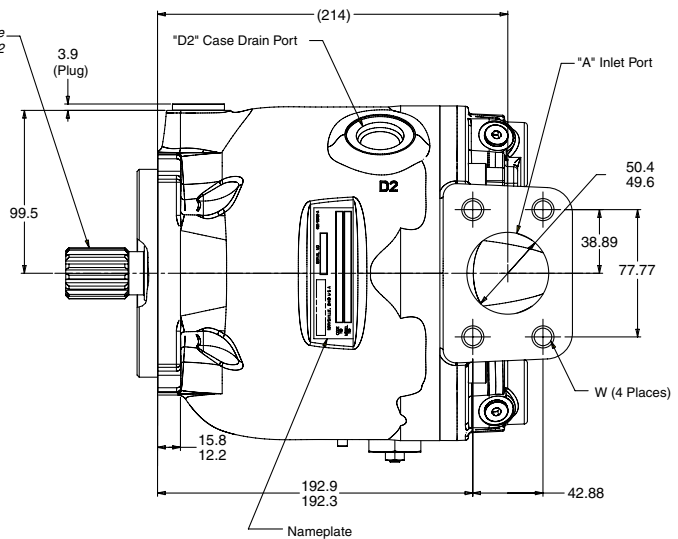
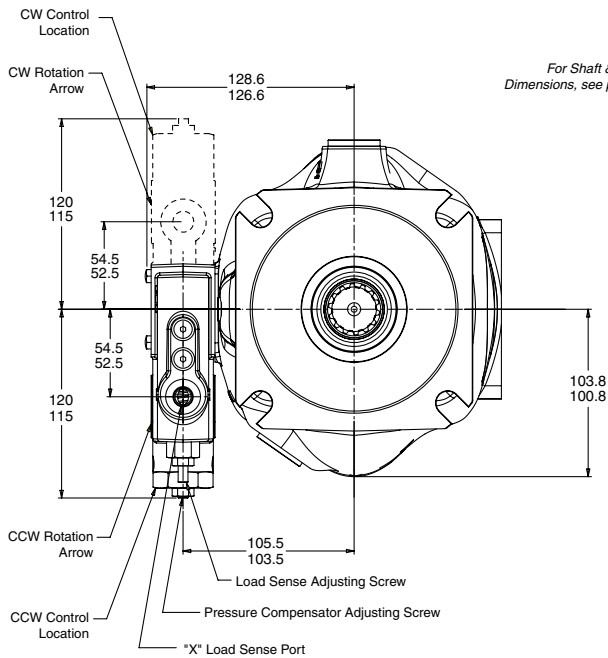
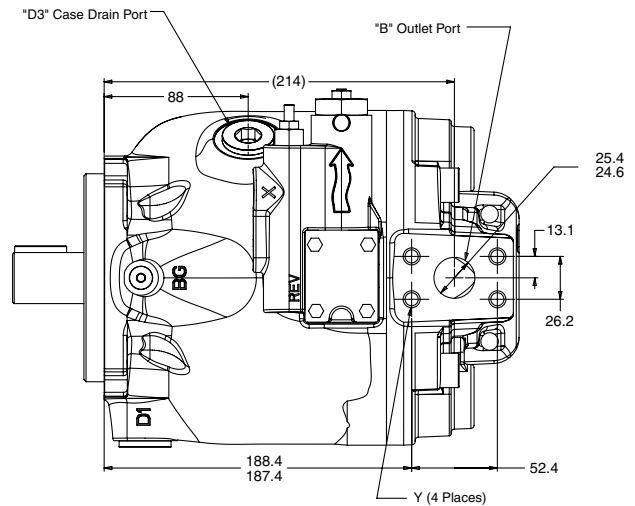

	PD075 Port Sizes		
	SAE	ISO	BSP
∅A Inlet	50mm code 61 ^C	50mm DN 51 ^B	—
W Threads	½ - 13 UNC-2B ^C	M12 x 1.75 ^B	—
∅B Outlet	25mm code 61 ^C	25mm DN25 ^B	—
Y Threads	⅜ - 16 UNC-2B ^C	M10 x 1.5 ^B	—
BG	SAE-4 ^D	M12x1.5 ^A	¼" ^E
D1 D2 D3	SAE-12 ^D	M27x2 ^A	¾" ^E
X	SAE-4 ^D	M12x1.5 ^A	¼" ^E

Note A: Metric o-ring boss port conform to ISO 6149-1
 Note B: Metric 4-bolt flange port conforms to ISO 6162
 Note C: Inch 4-bolt flange port conforms to SAE J518
 Note D: Inch o-ring boss port conforms to SAE J514
 Note E: BSP boss port conforms to ISO 228-1

Pump Installation - PD075
Side Ports with Thru-Drive
“L” Control Option

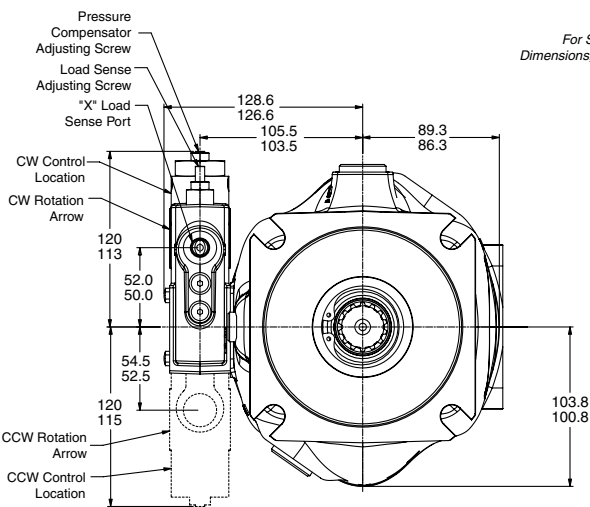

For Shaft & Spline Dimensions, see page 22

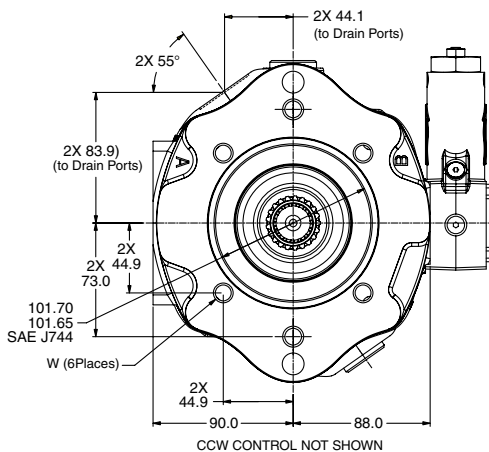
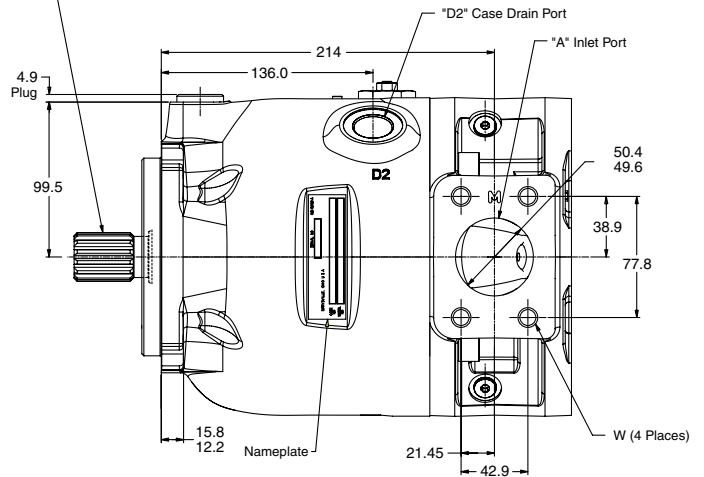
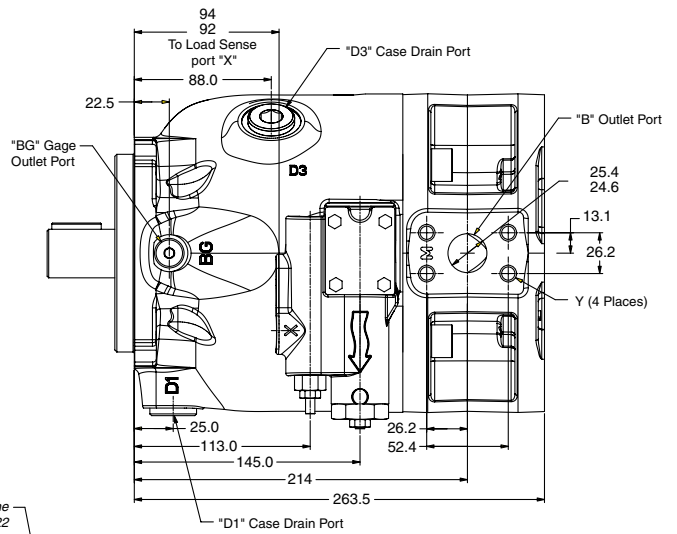

	PD075 Port Sizes		
	SAE	ISO	BSP
∅A Inlet	50mm code 61 ^C	50mm DN 51 ^B	—
W Threads	½ - 13 UNC-2B ^C	M12 x 1.75 ^B	—
∅B Outlet	25mm code 61 ^C	25mm DN25 ^B	—
Y Threads	⅜ - 16 UNC-2B ^C	M10 x 1.5 ^B	—
BG	SAE-4 ^D	M12x1.5 ^A	¼" ^E
D1 D2 D3	SAE-12 ^D	M27x2 ^A	¾" ^E
X	SAE-4 ^D	M12x1.5 ^A	¼" ^E

Note A: Metric o-ring boss port conform to ISO 6149-1
 Note B: Metric 4-bolt flange port conforms to ISO 6162
 Note C: Inch 4-bolt flange port conforms to SAE J518
 Note D: Inch o-ring boss port conforms to SAE J514
 Note E: BSP boss port conforms to ISO 228-1

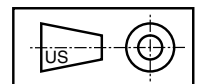

Shaft Location	PD075 Shaft Size & Type	Shaft Torque Capacity (Nm)
Input End	SAE C 32-1 Key	562
	SAE C 14T Spline	915
	ISO E32N Key	576
	ISO 14T Spline	915
Thru-Drive End	Spline Coupling	458

Dimensional Data

**Pump Installation - PD100
Input Shafts**

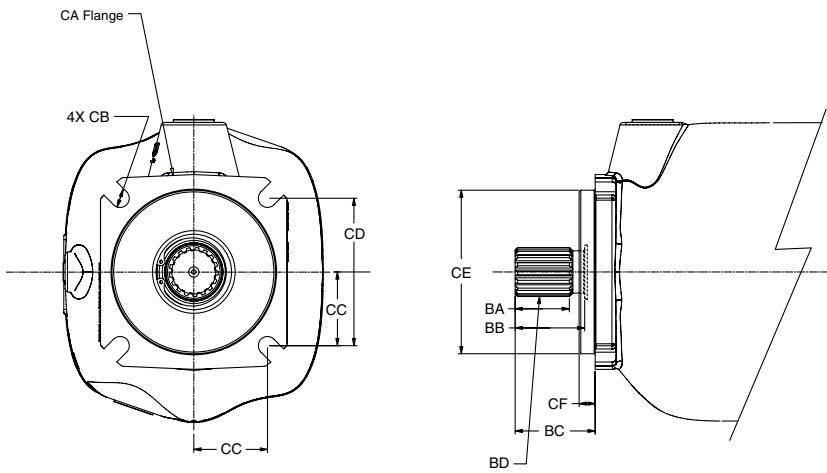
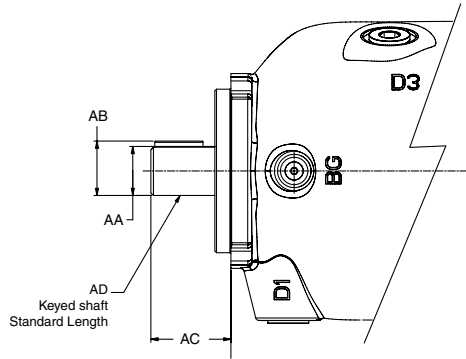

PD100	ISO	SAE
AA	40.021/40.002	38.10/38.05
AB	43.00/42.71	42.35/42.17
AC	92.8/91.2	62.8/61.2
AD	ISO E40N	SAE J744 38.1(C-C)
BA	20.0	42.1
BB	45.0	54.0
BC	56.0/55.0	62.8/61.2
BD	SPLINE: ISO 3019/2-2001-P40N (REF DIN 5480) INVOLUTE SPLINE DATA FLAT ROOT SIDE FIT NUMBER OF TEETH - 18 MODULE - M2 PRESSURE ANGLE - 30 MAJOR DIAMETER - 39.60 TOOTH THICKNESS - 9e	SPLINE: SAE ASA-B 1960 SAE 38-4(C-C) INVOLUTE SPLINE DATA CLASS 2 FLAT ROOT SIDE FIT NUMBER OF TEETH - 17 PITCH - 12/24 PRESSURE ANGLE - 30 MAJOR DIAMETER - 1.4793/1.4763 IN PITCH DIAMETER - 1.4167
CA	ISO 3019/2-2001 125B2SW	SAE J744 JUN96 127-4 C
CB	13.77/13.50	14.4 DIA.
CC	56.6	57.2
CD	113.2 SQUARE	114.5 SQUARE
CE	125.00/124.94 ISO 3019/2	127.00/126.95 SAE J744
CF	9.5/9.0	12.7/12.2

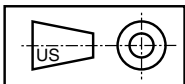

Pump Installation - PD100
End Ports
"L" Control Option

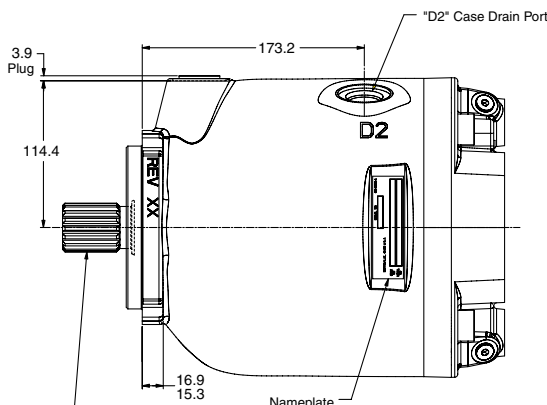
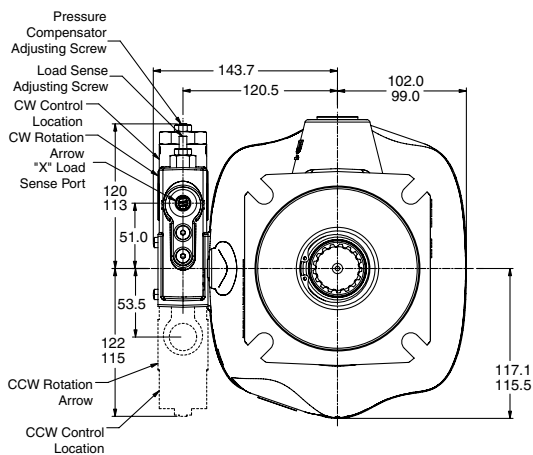
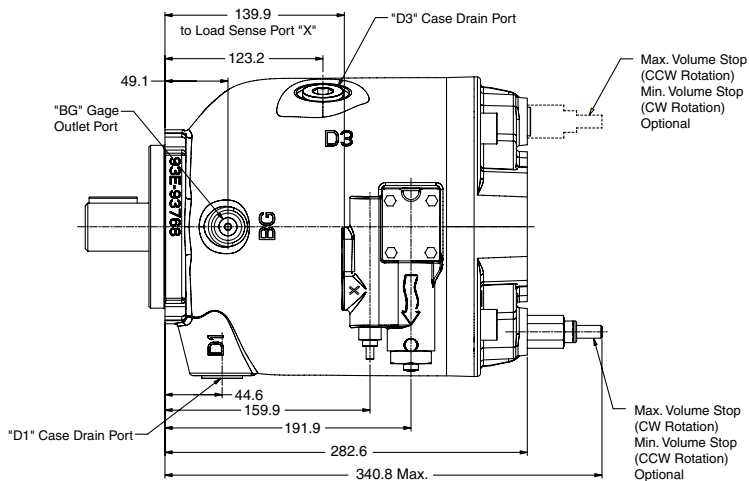

For Shaft & Spline Dimensions, see page 26

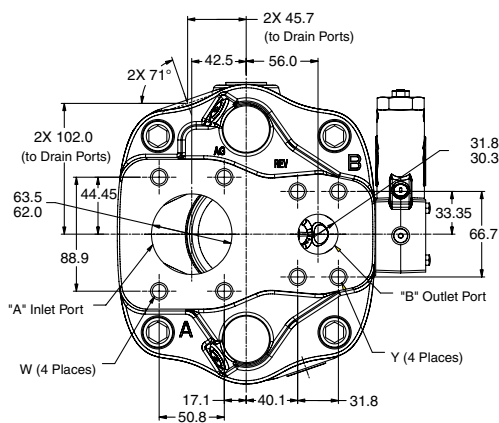

	PD100 Port Sizes		
	SAE	ISO	BSP
∅A Inlet	63mm code 61 ^C	63mm DN 64 ^B	—
W Threads	½ - 13 UNC-2B ^C	M12 x 1.75 ^B	—
∅B Outlet	32mm code 62 ^C	32mm DN 32 ^B	—
Y Threads	½ - 13 UNC-2B ^C	M12 x 1.75 ^B	—
BG	SAE-4 ^D	M12x1.5 ^A	¼" ^E
D1 D2 D3	SAE-12 ^D	M27x2 ^A	¾" ^E
X	SAE-4 ^D	M12x1.5 ^A	¼" ^E

Note A: Metric o-ring boss port conform to ISO 6149-1
 Note B: Metric 4-bolt flange port conforms to ISO 6162
 Note C: Inch 4-bolt flange port conforms to SAE J518
 Note D: Inch o-ring boss port conforms to SAE J514
 Note E: BSP boss port conforms to ISO 228-1

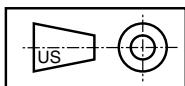

**Pump Installation - PD100
 Side Ports
 "L" Control Option**

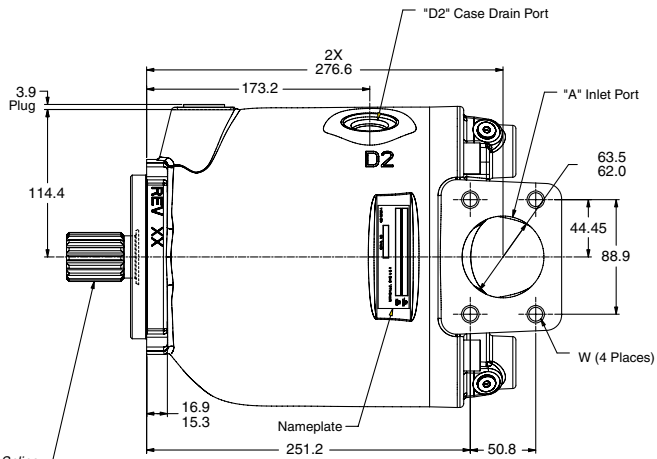
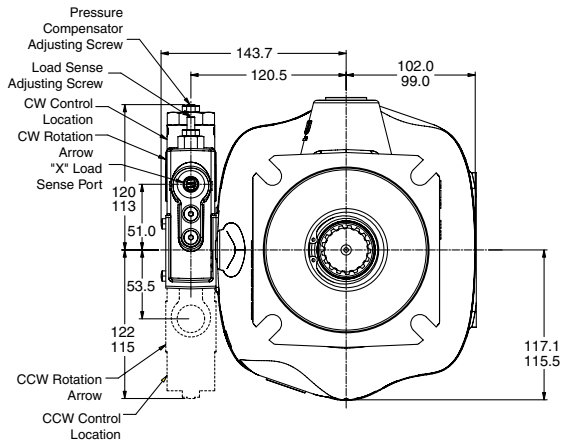
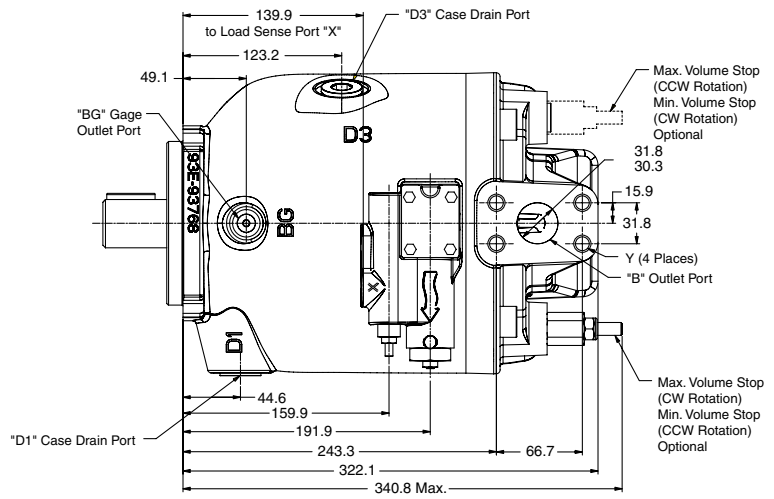

For Shaft & Spline
 Dimensions, see page 26

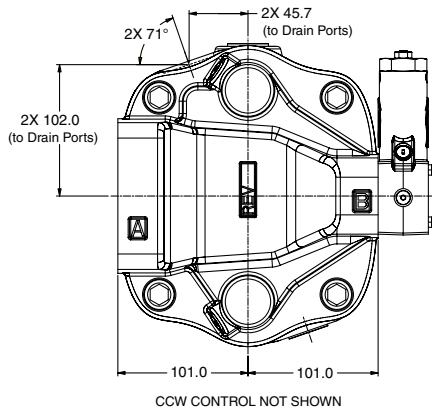

	PD100 Port Sizes		
	SAE	ISO	BSP
ØA Inlet	63mm code 61 ^C	63mm DN 64 ^B	—
W Threads	½ - 13 UNC-2B ^C	M12 x 1.75 ^B	—
ØB Outlet	32mm code 62 ^C	32mm DN 32 ^B	—
Y Threads	½ - 13 UNC-2B ^C	M12 x 1.75 ^B	—
BG	SAE-4 ^D	M12x1.5 ^A	¼" ^E
D1 D2 D3	SAE-12 ^D	M27x2 ^A	¾" ^E
X	SAE-4 ^D	M12x1.5 ^A	¼" ^E

Note A: Metric o-ring boss port conform to ISO 6149-1
 Note B: Metric 4-bolt flange port conforms to ISO 6162
 Note C: Inch 4-bolt flange port conforms to SAE J518
 Note D: Inch o-ring boss port conforms to SAE J514
 Note E: BSP boss port conforms to ISO 228-1

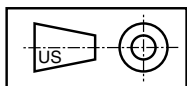

Pump Installation - PD100
Side Ports with Thru-Drive
“L” Control Option

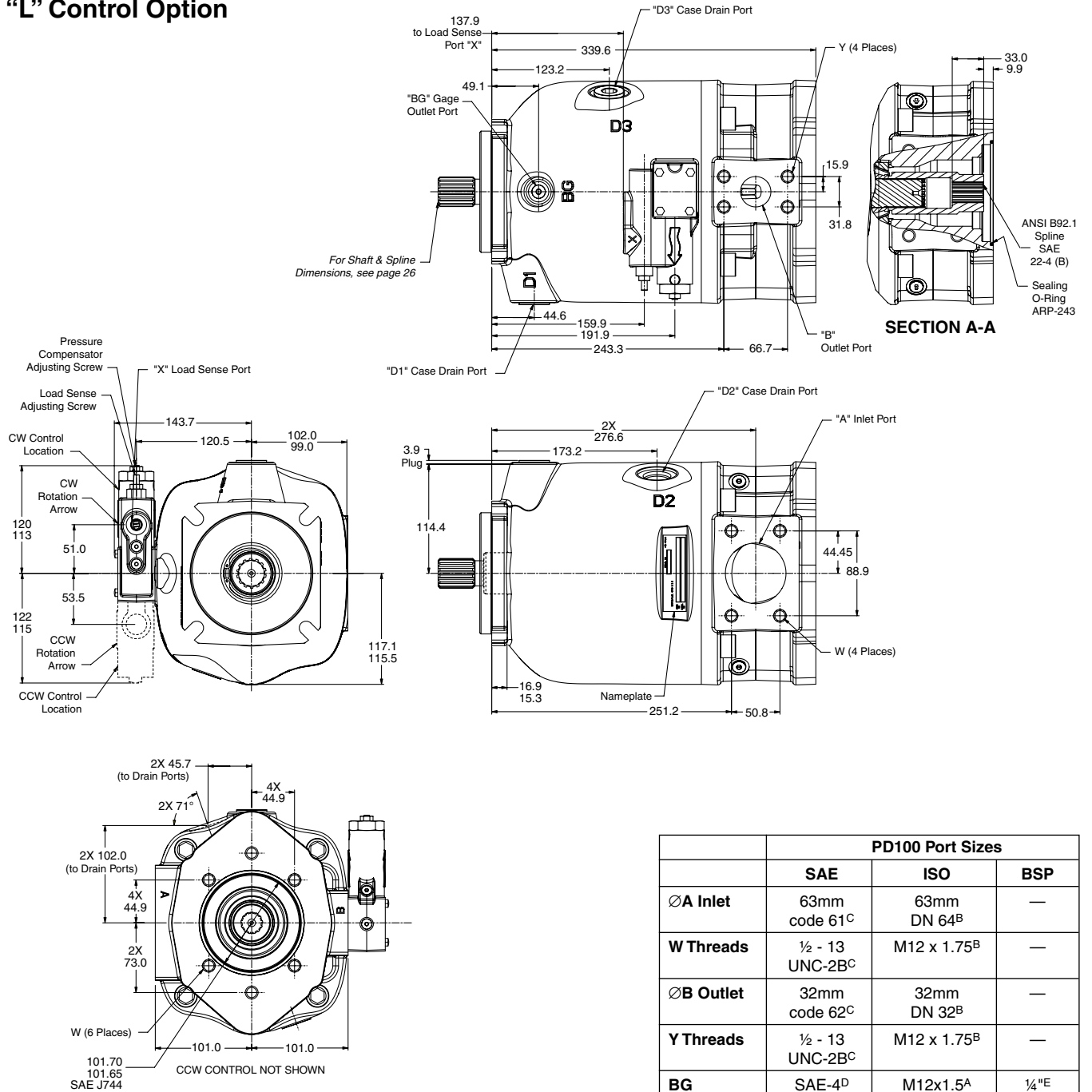

	PD100 Port Sizes		
	SAE	ISO	BSP
∅A Inlet	63mm code 61 ^C	63mm DN 64 ^B	—
W Threads	½ - 13 UNC-2B ^C	M12 x 1.75 ^B	—
∅B Outlet	32mm code 62 ^C	32mm DN 32 ^B	—
Y Threads	½ - 13 UNC-2B ^C	M12 x 1.75 ^B	—
BG	SAE-4 ^D	M12x1.5 ^A	¼" ^E
D1 D2 D3	SAE-12 ^D	M27x2 ^A	¾" ^E
X	SAE-4 ^D	M12x1.5 ^A	¼" ^E

Note A: Metric o-ring boss port conform to ISO 6149-1
 Note B: Metric 4-bolt flange port conforms to ISO 6162
 Note C: Inch 4-bolt flange port conforms to SAE J518
 Note D: Inch o-ring boss port conforms to SAE J514
 Note E: BSP boss port conforms to ISO 228-1

Shaft Location	PD100 Shaft Size & Type	Shaft Torque Capacity (Nm)
Input End	SAE C-C 38-1 Key	980
	SAE C-C 17T Spline	1220
	ISO E40N Key	1157
	ISO 18T Spline	1220
Thru-Drive End	Spline Coupling	610

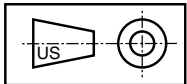

Dimensional Data

**Pump Installation - PD140
Input Shafts**

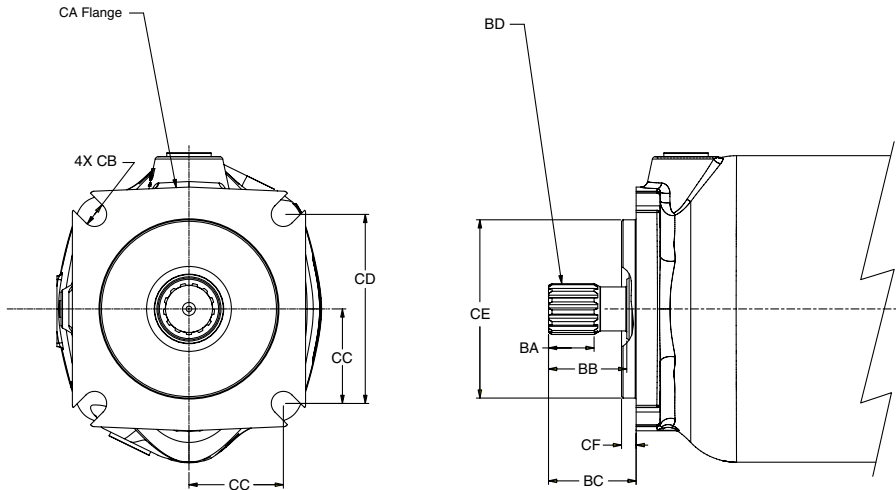
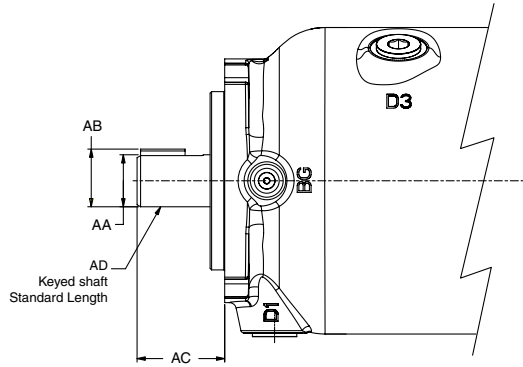

PD140	ISO	SAE
ØAA	50.027/50.002	44.45/44.40
AB	53.50/53.21	49.43/49.17
AC	92.8/91.2	75.8/74.2
AD	ISO E50N	SAE J744 44-1(D)
BA	41.0	39.0
BB	55.0	67.0
BC	66.0/65.0	75.8/74.2
BD	SPLINE: ISO 3019/2-2001-P50N (REF DIN 5480) INVOLUTE SPLINE DATA FLAT ROOT SIDE FIT NUMBER OF TEETH - 24 MODULE - M2 PRESSURE ANGLE - 30 MAJOR DIAMETER - 49.60 TOOTH THICKNESS TOLERANCE - 9g	SPLINE: SAE J498-B 1969 SAE 44-4(D) INVOLUTE SPLINE DATA CLASS 1 FLAT ROOT SIDE FIT NUMBER OF TEETH - 13 PITCH - 8/16 PRESSURE ANGLE - 30 MAJOR DIAMETER - 1.7210/1.7160 IN PITCH DIAMETER - 1.6250
CA	ISO 3019/2-2001 180B4SW	SAE J744 JUN96 152-4(D)
CB	18.20/17.80	20.9/20.5 DIA.
CC	79.2	80.8
CD	158.4 SQUARE	161.6 SQUARE
CE	180.00/179.95 ISO 3019/2	152.40/152.35 SAE J744
CF	9.5/9.0	12.7/12.2

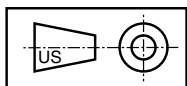

**Pump Installation - PD140
 End Ports
 "L" Control Option**

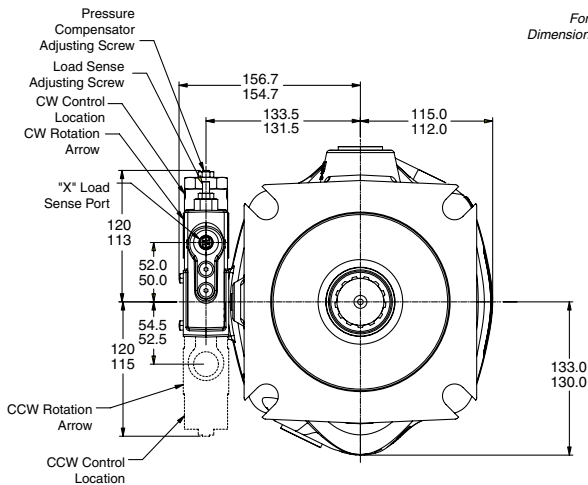
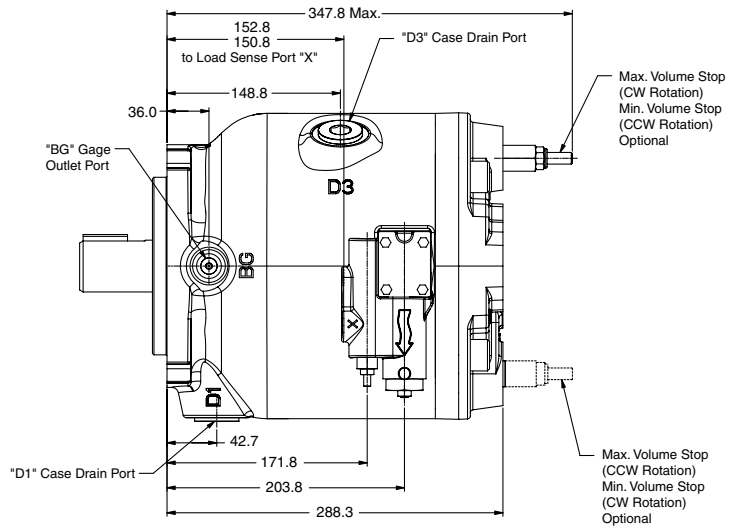

For Shaft & Spline
 Dimensions, see page 30

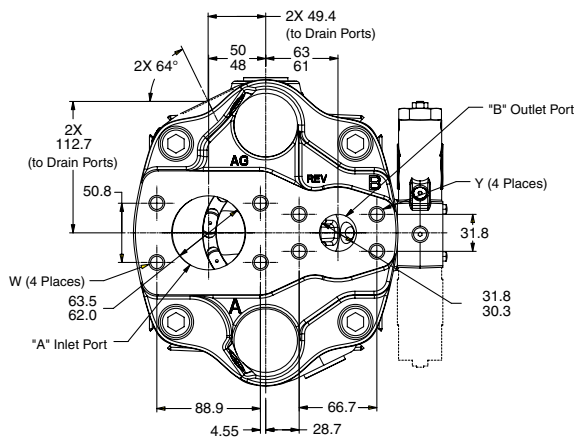
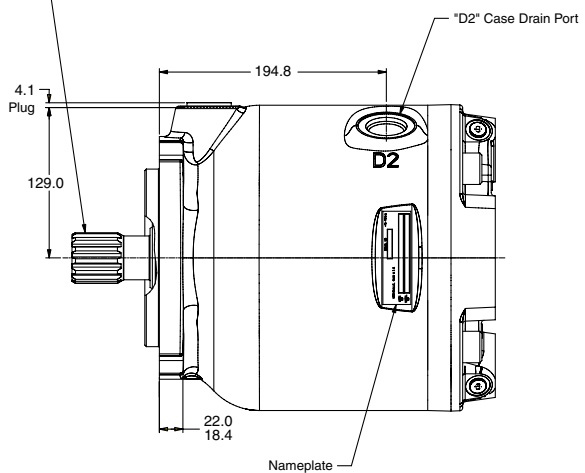

	PD140 Port Sizes		
	SAE	ISO	BSP
∅A Inlet	63mm code 61 ^C	63mm DN 64 ^B	—
W Threads	½ - 13 UNC-2B ^C	M12 x 1.75 ^B	—
∅B Outlet	32mm code 62 ^C	32mm DN 32 ^B	—
Y Threads	½ - 13 UNC-2B ^C	M12 x 1.75 ^B	—
BG	SAE-4 ^D	M12x1.5 ^A	¼" ^E
D1 D2 D3	SAE-16 ^D	M33x2 ^A	1" ^E
X	SAE-4 ^D	M12x1.5 ^A	¼" ^E

Note A: Metric o-ring boss port conform to ISO 6149-1
 Note B: Metric 4-bolt flange port conforms to ISO 6162
 Note C: Inch 4-bolt flange port conforms to SAE J518
 Note D: Inch o-ring boss port conforms to SAE J514
 Note E: BSP boss port conforms to ISO 228-1

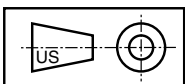

Dimensional Data

Pump Installation - PD140
Side Ports
"L" Control Option

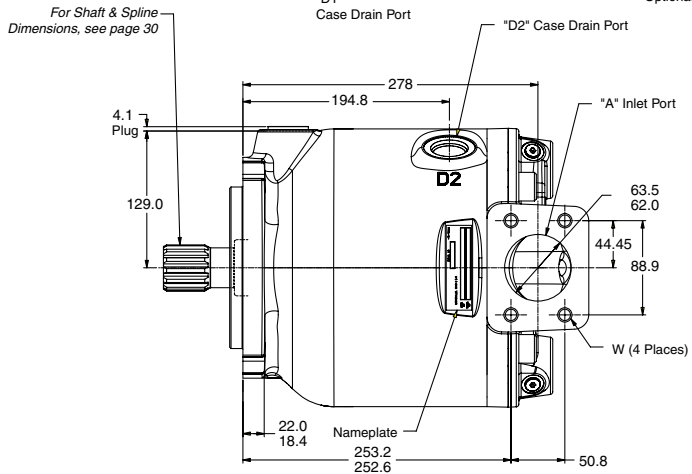
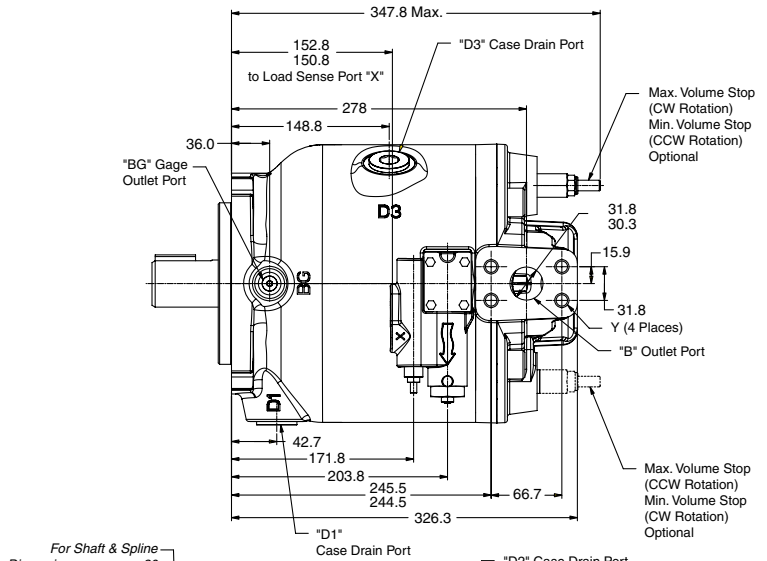
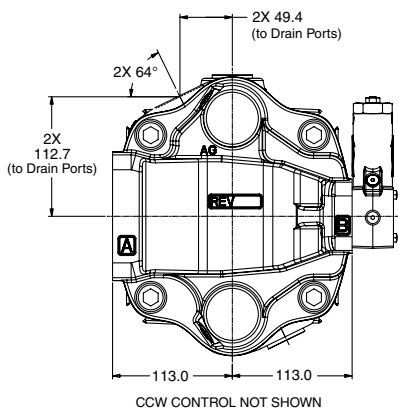
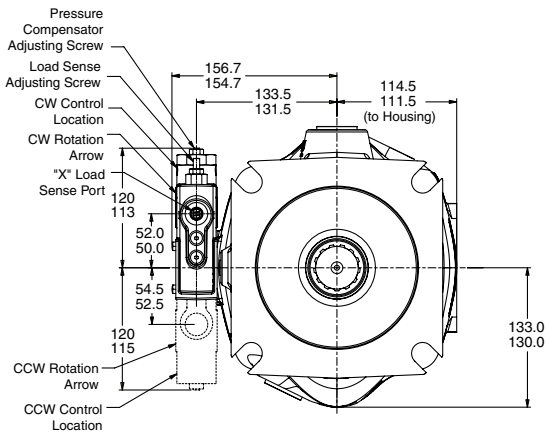

	PD140 Port Sizes		
	SAE	ISO	BSP
ØA Inlet	63mm code 61 ^C	63mm DN 64 ^B	—
W Threads	½ - 13 UNC-2B ^C	M12 x 1.75 ^B	—
ØB Outlet	32mm code 62 ^C	32mm DN 32 ^B	—
Y Threads	½ - 13 UNC-2B ^C	M12 x 1.75 ^B	—
BG	SAE-4 ^D	M12x1.5 ^A	¼" ^E
D1 D2 D3	SAE-16 ^D	M33x2 ^A	1" ^E
X	SAE-4 ^D	M12x1.5 ^A	¼" ^E

Note A: Metric o-ring boss port conform to ISO 6149-1
 Note B: Metric 4-bolt flange port conforms to ISO 6162
 Note C: Inch 4-bolt flange port conforms to SAE J518
 Note D: Inch o-ring boss port conforms to SAE J514
 Note E: BSP boss port conforms to ISO 228-1

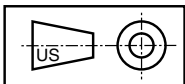

Dimensional Data

**Pump Installation - PD140
Side Ports with Thru-Drive
"L" Control Option**

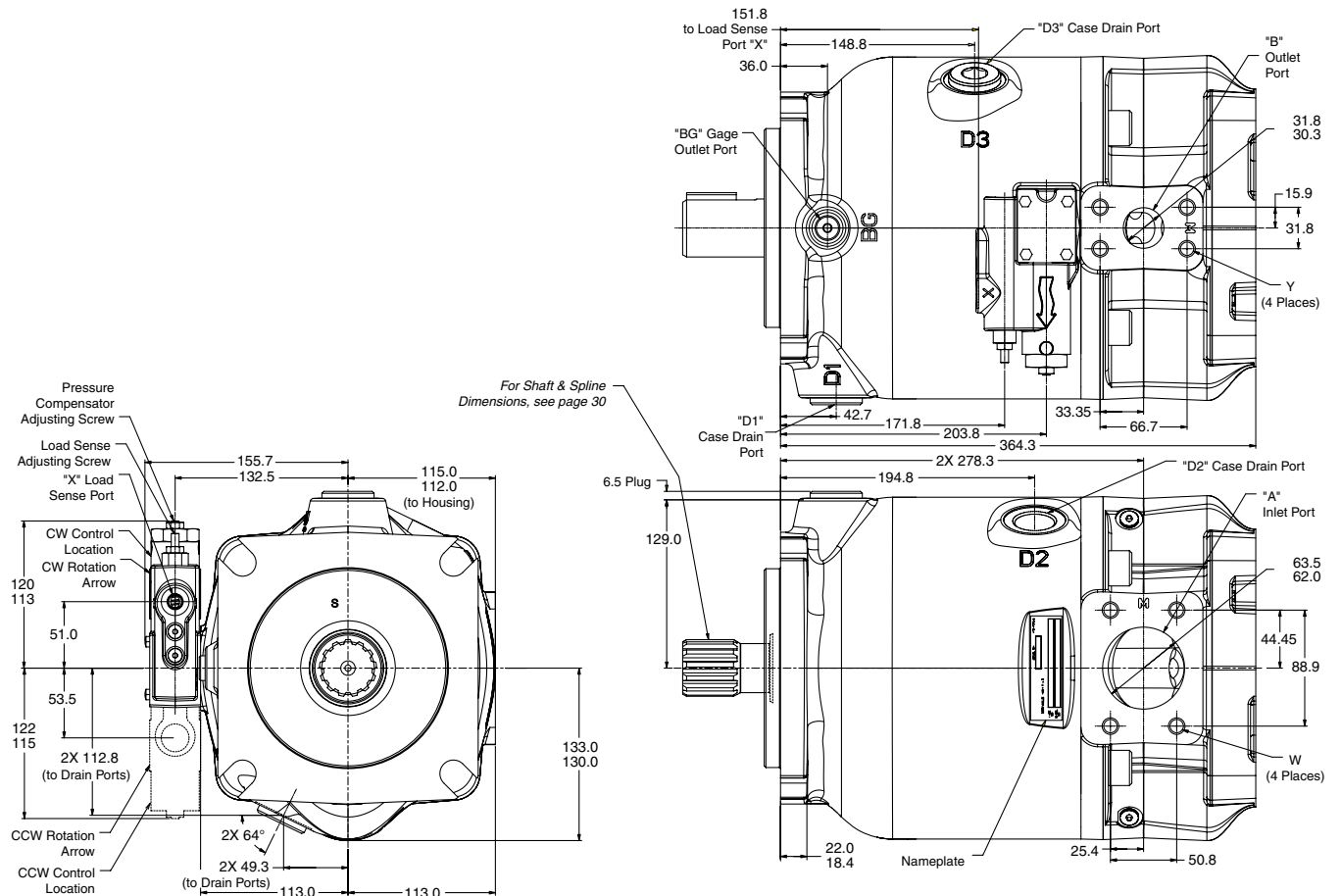

Shaft Location	PD140 Shaft Size & Type	Shaft Torque Capacity (Nm)
Input End	SAE D 44-1 Key	1708
	SAE D 13T Spline	1708
	ISO E50N Key	1708
	ISO 24T Spline	1708
Thru-Drive End	Spline Coupling	854

	PD140 Port Sizes		
	SAE	ISO	BSP
∅A Inlet	63mm code 61 ^C	63mm DN 64 ^B	—
W Threads	½ - 13 UNC-2B ^C	M12 x 1.75 ^B	—
∅B Outlet	32mm code 62 ^C	32mm DN 32 ^B	—
Y Threads	½ - 13 UNC-2B ^C	M12 x 1.75 ^B	—
BG	SAE-4 ^D	M12x1.5 ^A	¼" ^E
D1 D2 D3	SAE-16 ^D	M33x2 ^A	1" ^E
X	SAE-4 ^D	M12x1.5 ^A	¼" ^E

Note A: Metric o-ring boss port conform to ISO 6149-1
 Note B: Metric 4-bolt flange port conforms to ISO 6162
 Note C: Inch 4-bolt flange port conforms to SAE J518
 Note D: Inch o-ring boss port conforms to SAE J514
 Note E: BSP boss port conforms to ISO 228-1

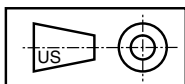

Dimensional Data

**Pump Installation - PD140
Side Ports with Thru-Drive
Mounting Options**

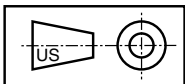
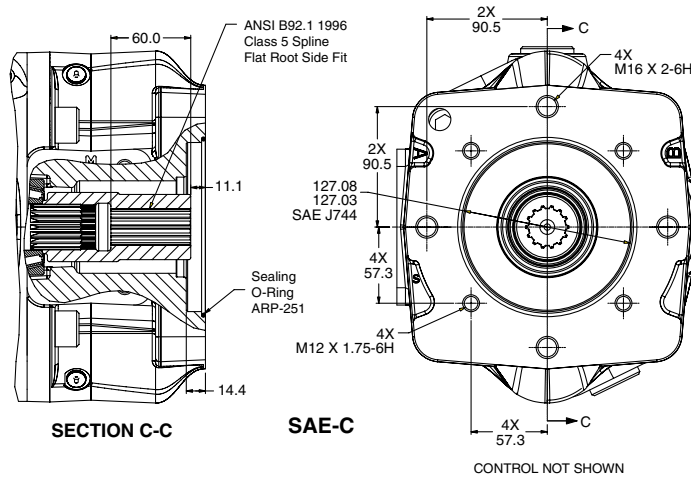
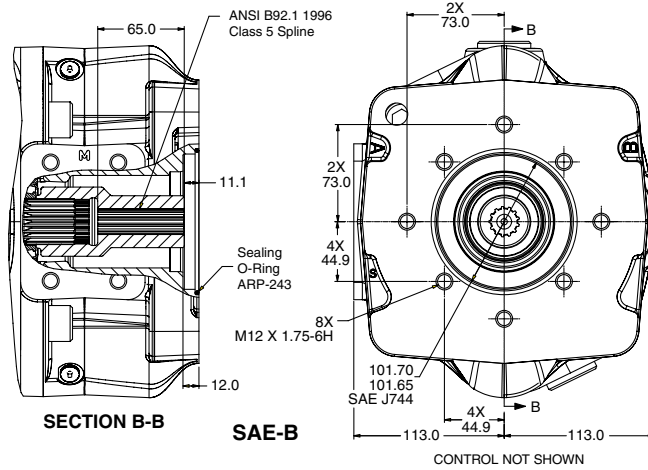

C Control**
Pressure Limiter

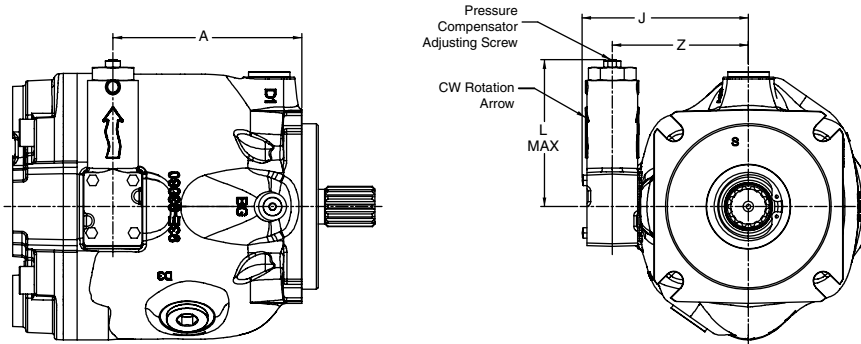

CW ORIENTATION
P*075 Shown

C CONTROL**

ADJUSTMENT SENSITIVITY

C00	40 Bar per Turn
C10	18.6 Bar per Turn

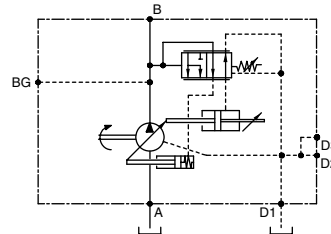

CCW ORIENTATION
P*075 Shown

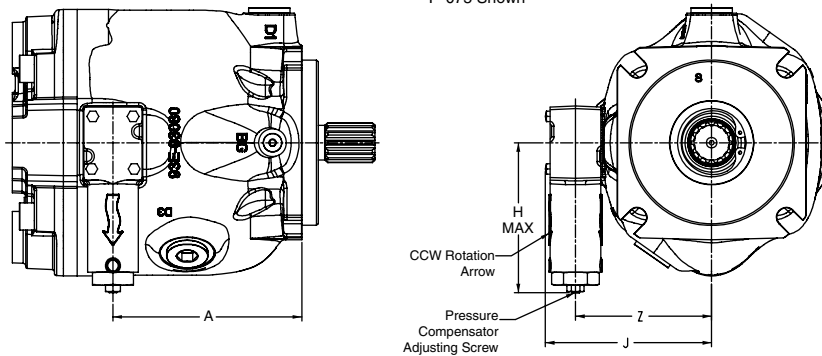

Dimensions

Model	A	H Max	J	L Max	Z
P*060	134.5	122	124.7	120	101.5
P*075	145.0	122	127.7	120	104.5
P*100	191.9	122	143.7	120	120.5
P*140	203.8	122	155.7	120	132.5

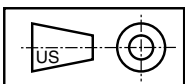

Dimensional Data

L Control**

Load Sensing with Pressure Limiter

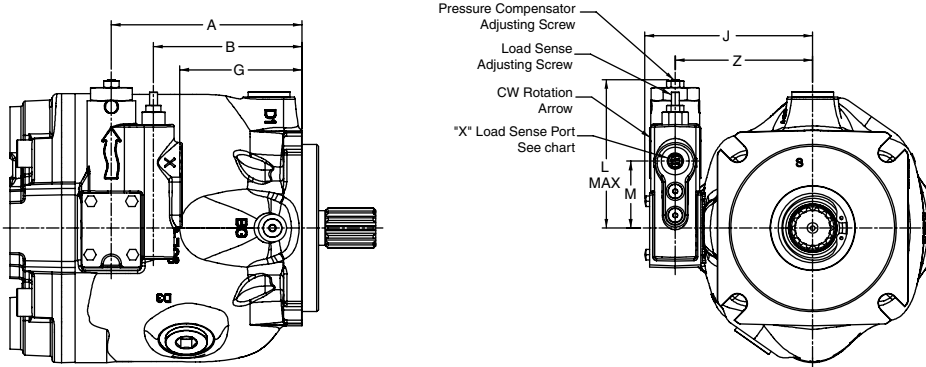

CW ORIENTATION
P*075 Shown

L CONTROL**

ADJUSTMENT SENSITIVITY	
Load Sense	28 Bar per Turn
Pressure Compensator L0	40 Bar per Turn
Pressure Compensator L1	18.6 Bar per Turn

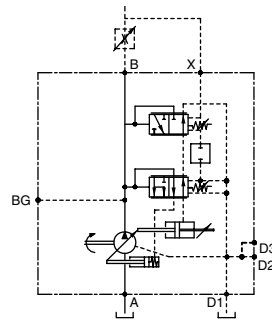

CCW ORIENTATION
P*075 Shown

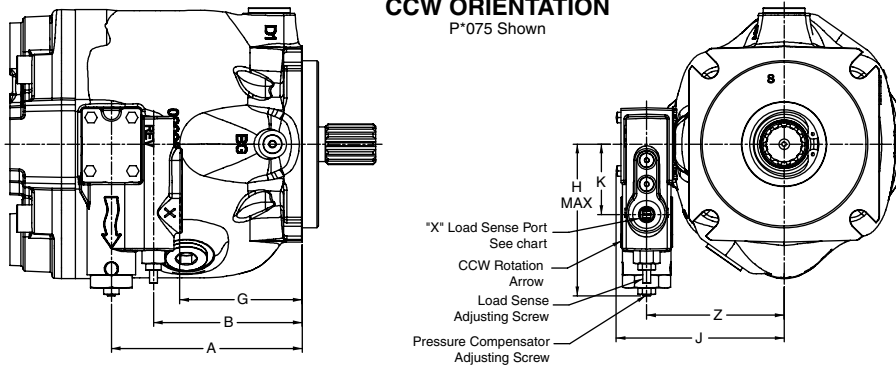

LOAD SENSE PORT "X"	
P****PS	SAE J514 Straight Thread O-Ring Port 7/16-20 UNF-2B (SAE-4)
P****PA	1/4" BSPP per ISO 228-1
P****PB	1/4" BSPP per ISO 228-1
P****PM	M12 x 1.5-6H per ISO 6149-1

Dimensions

Model	A	B	G	H Max	J	K	L Max	M	Z
P*060	134.5	102.5	82.5	122	124.7	53.5	120	51.0	101.5
P*075	145.0	113.0	93.0	122	127.7	53.5	120	51.0	104.5
P*100	191.9	159.9	139.9	122	143.7	53.5	120	51.0	120.5
P*140	203.8	171.8	151.8	122	155.7	53.5	120	51.0	132.5

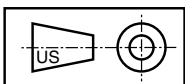

RN Control
 Control with ISO 4401 Interface and Shipping Cover

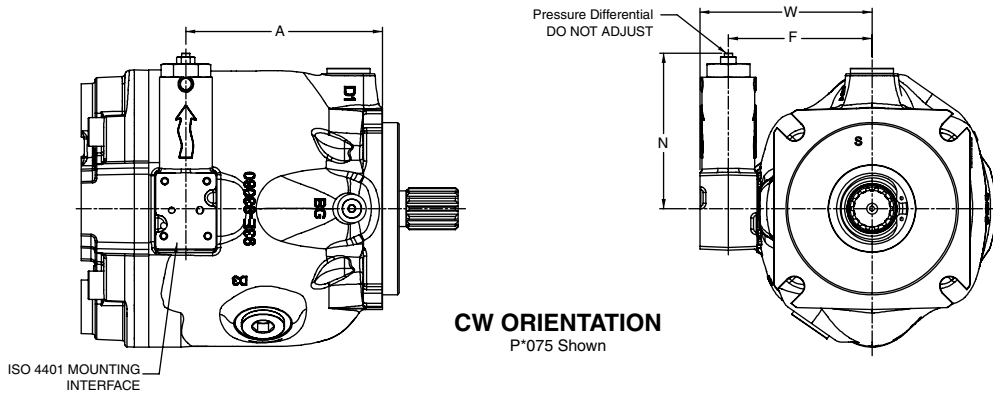

RN CONTROL

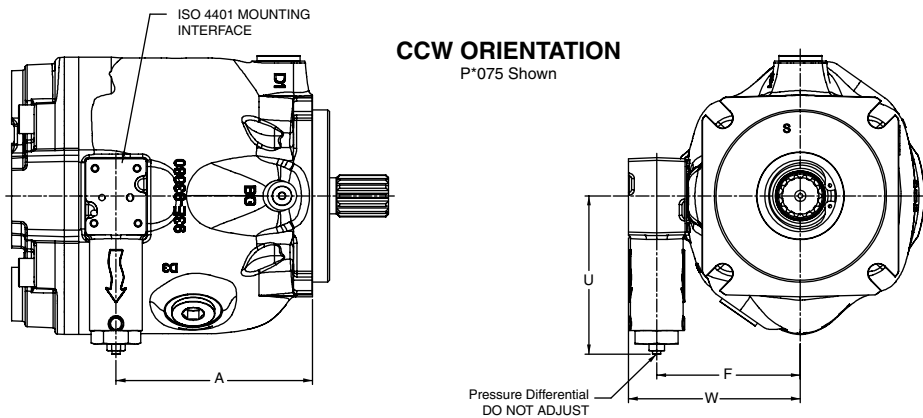
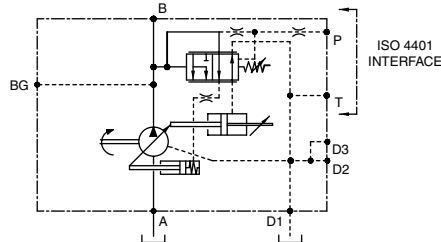

Dimensions

Model	A	F	N	U	W
P*060	134.5	103.0	114.6	116.8	124.0
P*075	145.0	106.0	114.6	116.8	127.0
P*100	191.9	122.0	114.6	116.8	143.0
P*140	203.8	134.0	114.6	116.8	155.0

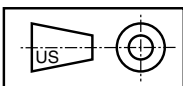

Dimensional Data

RH Control
Remote Pilot Operated Pressure Limiter

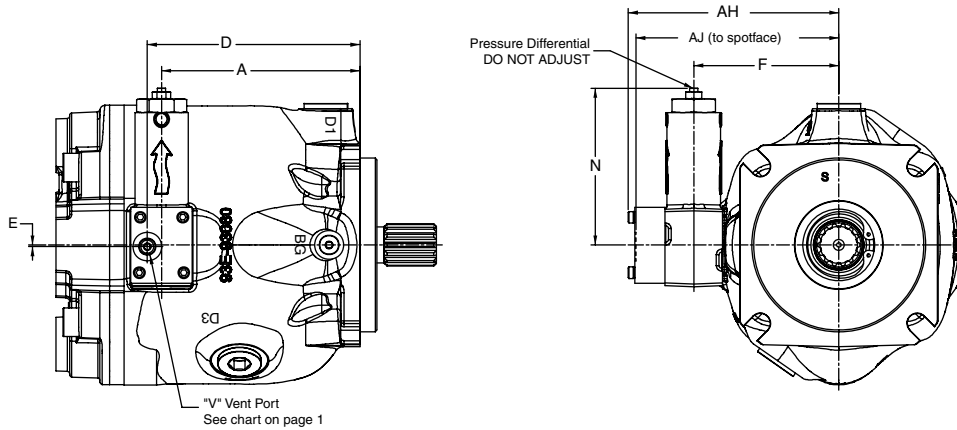

CW ORIENTATION

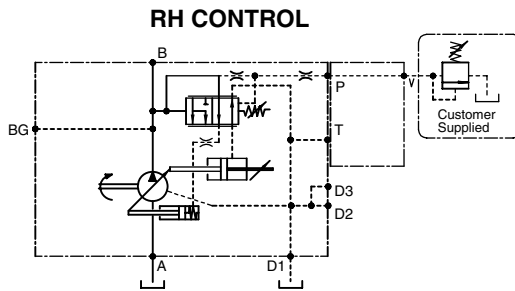

CCW ORIENTATION
P*075 Shown

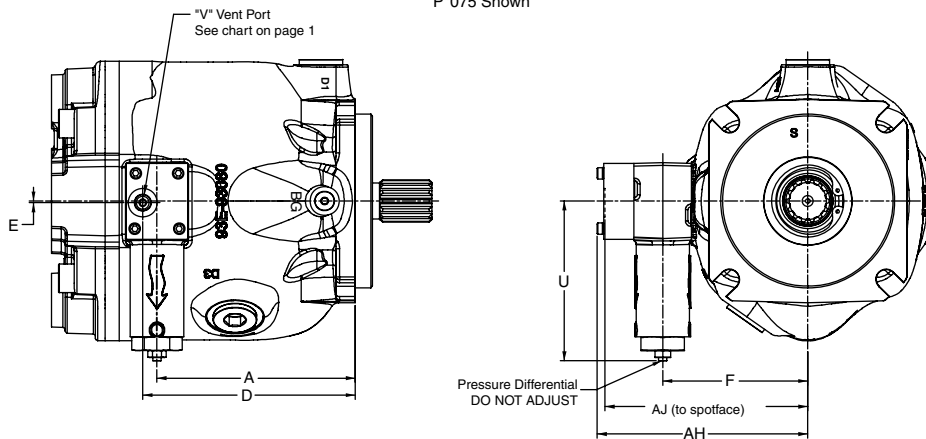

Dimensions

Model	A	D	E	F	N	U	AH	AJ
P*060	134.5	144.9	1.3	103.0	114.6	116.8	150.9	145.2
P*075	145.0	155.4	1.3	106.0	114.6	116.8	153.9	148.2
P*100	191.9	202.3	1.3	122.0	114.6	116.8	169.9	164.2
P*140	203.8	214.2	1.3	134.0	114.6	116.8	181.9	176.2

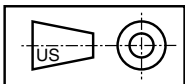

RM Control
Pilot Operated Pressure Limiter
with Mechanical Adjustment and Vent Port

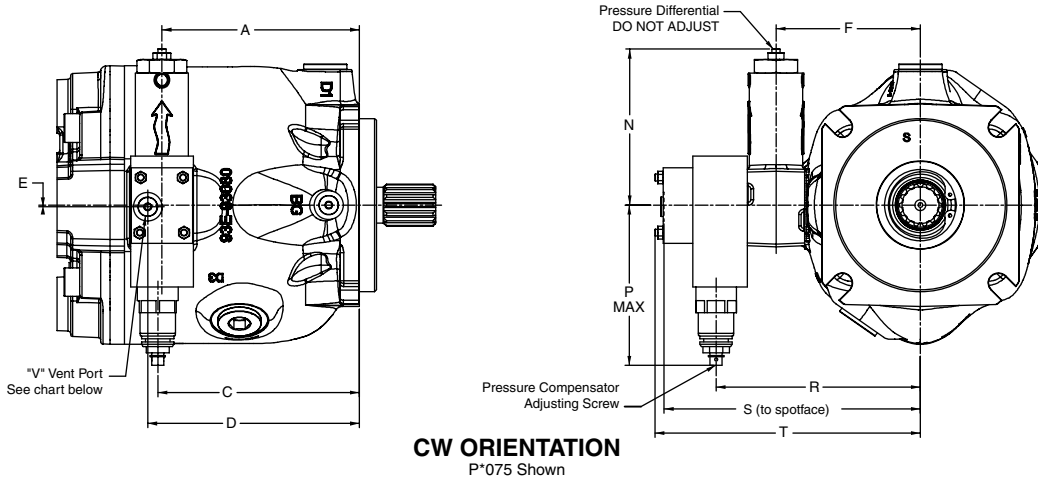

RM CONTROL

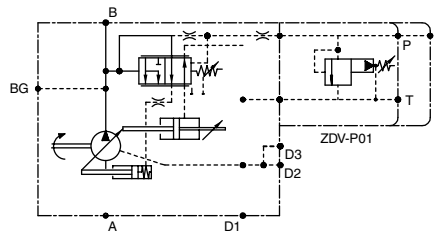

CCW ORIENTATION

P*075 Shown

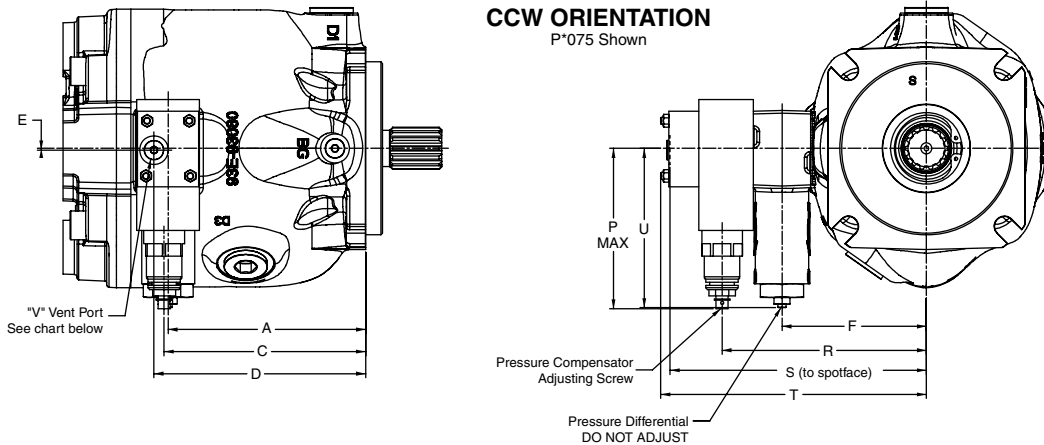

Model	Vent Port "V"
P****PS	SAE J514 Straight Thread O-Ring Port 7/16-20 UNF-2B (SAE-4)
P****PA	1/4" BSPP per ISO 228-1
P****PB	1/4" BSPP per ISO 228-1
P****PM	M12 x 1.5-6H per ISO 6149-1

Dimensions

Model	A	C	D	E	F	N	P Max	R	S	T	U
P*060	134.5	137.5	144.9	1.3	103.0	114.6	117.8	147	185.2	192.0	116.8
P*075	145.0	148.0	155.4	1.3	106.0	114.6	117.8	150.0	188.2	195.0	116.8
P*100	191.9	194.9	202.3	1.3	122.0	114.6	117.8	166.0	204.2	211.0	116.8
P*140	203.8	206.8	214.2	1.3	134.0	114.6	117.8	178.0	216.2	223.0	116.8

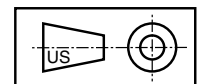

Dimensional Data

RE Control
Pilot Operated Pressure Limiter with Electrical Adjustment

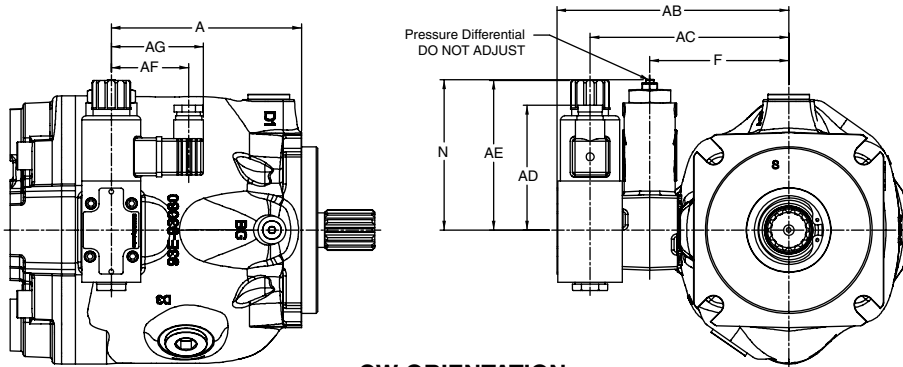

CW ORIENTATION
P*075 Shown

THE FOLLOWING ARE RECOMMENDED TO DRIVE THE 4VP01 VALVE

PART NUMBER	DESCRIPTION
701-00600-8	Proportional Amplifier
701-00007-8	Card Holder
701-00023-8	Power Supply
701-00066-8	Card Holder
701-00013-8	Potentiometer
REFERENCE	3-EN 2200-B
REFERENCE	9-EN601-A for Setup

RE CONTROL

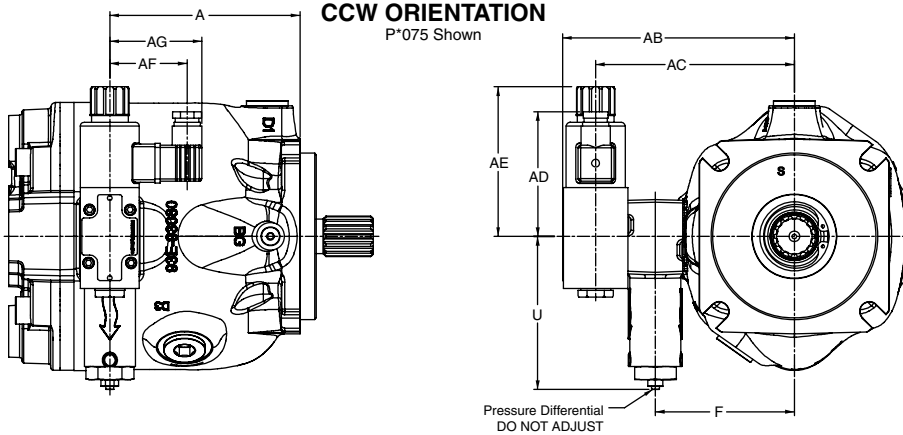
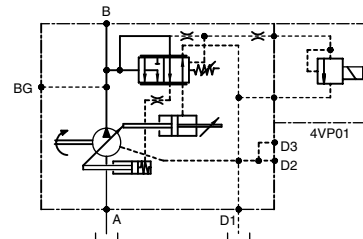

CCW ORIENTATION
P*075 Shown

Dimensions

Model	A	F	N	U	Z	AB	AC	AD	AE	AF	AG
P*060	134.5	103.0	114.6	116.8	101.5	173.8	148.5	95.1	114.1	R59.0	R70.2
P*075	145.0	106.0	114.6	116.8	104.5	176.8	151.5	95.1	114.1	R59.0	R70.2
P*100	191.9	122.0	114.6	116.8	120.5	192.8	167.5	95.1	114.1	R59.0	R70.2
P*140	203.8	134.0	114.6	116.8	132.5	204.8	179.5	95.1	114.1	R59.0	R70.2

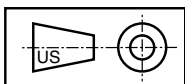

Dimensional Data

EY & GY Control

Integrated Digital Electronic Control (IDEC)
(075 only)

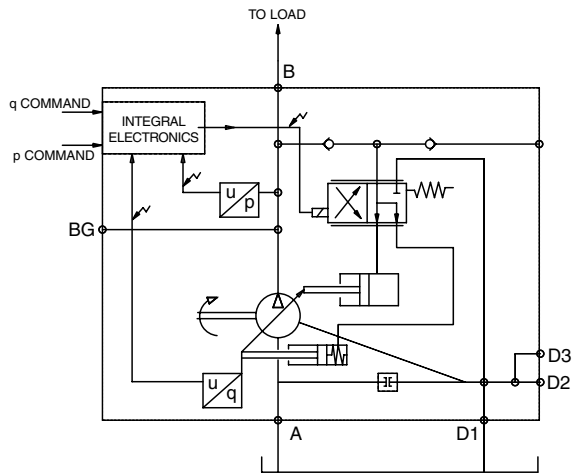
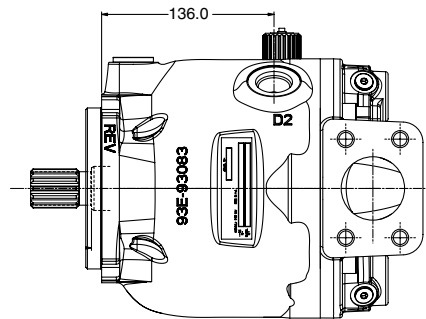
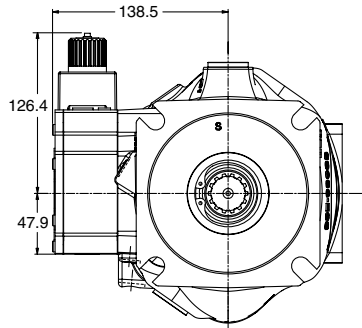

EY Option -(valve spring offset to zero displacement)

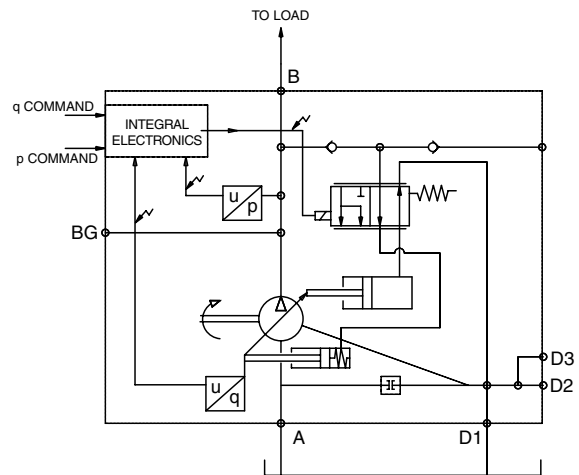

GY Option -(valve spring offset to max. displacement)

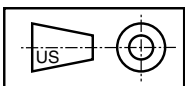

Extensive Hydraulic Product Offering

Accumulators



Piston, bladder and diaphragm type accumulators, gas bottles and KleenVent reservoir isolators.

www.parker.com/accumulator

Compact Hydraulics



Self-contained with a motor, gear pump, reservoir, internal valving, load hold checks and relief valves.

www.parker.com/oilydne

Cylinders



Standard and custom hydraulic cylinders for industrial and mobile applications.

www.parker.com/hydcyl

Electronics/Remote Controls



Parker's unique IQAN approach combines sturdy, well-tested hardware with intelligent, flexible computing power.

www.parker.com/iqan

Filtration



Pressure and return line filters enhances machine life, reduces maintenance and lowers costs.

www.parker.com/hydraulicfilter

Integrated Hydraulic Circuits



Solutions for complex circuits that include threaded cartridge valves integrated into a single manifold.

www.parker.com/hcs

Motors



Full line of high and low speed motors provides power up to 15,000 in-lbs of torque.

www.parker.com/pumpmotor

Power Take Off



Parker Chelsea leads the industry for engineering, innovation and performance in auxiliary power systems.

www.parker.com/chelsea

Power Units



The most complete line of standard, pre-engineered, cataloged hydraulic power units in the industry.

www.parker.com/pumpmotor

Pumps



Broad line of energy-efficient hydraulic pumps that includes piston, vane and gear pumps.

www.parker.com/mobpump

Rotary Actuator



Industry leader in the design and manufacture of hydraulic rack and pinion, and vane style rotary actuators.

www.parker.com/actuator

Valves and Controls



Hydraulic valves for virtually every hydraulic equipment application, from simple to precise control.

www.parker.com/hydraulicvalve

Covering the Industrial, Mobile and Truck markets, each catalog is paired with an interactive CD. Call for your comprehensive guides today. 800-CParker.



Industrial Driven
HY28-2661/US

Mobile Driven
HY28-2662/US

Truck Driven
HY28-2665/US

Parker Worldwide

AE – UAE, Dubai
Tel: +971 4 8127100
parker.me@parker.com

AR – Argentina, Buenos Aires
Tel: +54 3327 44 4129

AT – Austria, Wiener Neustadt
Tel: +43 (0)2622 23501-0
parker.austria@parker.com

AT – Eastern Europe, Wiener Neustadt
Tel: +43 (0)2622 23501 900
parker.easteurope@parker.com

AU – Australia, Castle Hill
Tel: +61 (0)2-9634 7777

AZ – Azerbaijan, Baku
Tel: +994 50 2233 458
parker.azerbaijan@parker.com

BE/LU – Belgium, Nivelles
Tel: +32 (0)67 280 900
parker.belgium@parker.com

BR – Brazil, Cachoeirinha RS
Tel: +55 51 3470 9144

BY – Belarus, Minsk
Tel: +375 17 209 9399
parker.belarus@parker.com

CA – Canada, Milton, Ontario
Tel: +1 905 693 3000

CH – Switzerland, Etoy
Tel: +41 (0) 21 821 02 30
parker.switzerland@parker.com

CL – Chile, Santiago
Tel: +56 2 623 1216

CN – China, Shanghai
Tel: +86 21 5031 2525

CZ – Czech Republic, Klecany
Tel: +420 284 083 111
parker.czechrepublic@parker.com

DE – Germany, Kaarst
Tel: +49 (0)2131 4016 0
parker.germany@parker.com

DK – Denmark, Ballerup
Tel: +45 43 56 04 00
parker.denmark@parker.com

ES – Spain, Madrid
Tel: +34 902 33 00 01
parker.spain@parker.com

FI – Finland, Vantaa
Tel: +358 (0)20 753 2500
parker.finland@parker.com

FR – France, Contamine s/Arve
Tel: +33 (0)4 50 25 80 25
parker.france@parker.com

GR – Greece, Athens
Tel: +30 210 933 6450
parker.greece@parker.com

HK – Hong Kong
Tel: +852 2428 8008

HU – Hungary, Budapest
Tel: +36 1 220 4155
parker.hungary@parker.com

IE – Ireland, Dublin
Tel: +353 (0)1 466 6370
parker.ireland@parker.com

IN – India, Mumbai
Tel: +91 22 6513 7081-85

IT – Italy, Corsico (MI)
Tel: +39 02 45 19 21
parker.italy@parker.com

JP – Japan, Fujisawa
Tel: +(81) 4 6635 3050

KR – South Korea, Seoul
Tel: +82 2 559 0400

KZ – Kazakhstan, Almaty
Tel: +7 7272 505 800
parker.easteurope@parker.com

LV – Latvia, Riga
Tel: +371 6 745 2601
parker.latvia@parker.com

MX – Mexico, Apodaca
Tel: +52 81 8156 6000

MY – Malaysia, Shah Alam
Tel: +60 3 7849 0800

NL – The Netherlands, Oldenzaal
Tel: +31 (0)541 585 000
parker.nl@parker.com

NO – Norway, Ski
Tel: +47 64 91 10 00
parker.norway@parker.com

NZ – New Zealand, Mt Wellington
Tel: +64 9 574 1744

PL – Poland, Warsaw
Tel: +48 (0)22 573 24 00
parker.poland@parker.com

PT – Portugal, Leca da Palmeira
Tel: +351 22 999 7360
parker.portugal@parker.com

RO – Romania, Bucharest
Tel: +40 21 252 1382
parker.romania@parker.com

RU – Russia, Moscow
Tel: +7 495 645-2156
parker.russia@parker.com

SE – Sweden, Spånga
Tel: +46 (0)8 59 79 50 00
parker.sweden@parker.com

SG – Singapore
Tel: +65 6887 6300

SK – Slovakia, Banská Bystrica
Tel: +421 484 162 252
parker.slovakia@parker.com

SL – Slovenia, Novo Mesto
Tel: +386 7 337 6650
parker.slovenia@parker.com

TH – Thailand, Bangkok
Tel: +662 717 8140

TR – Turkey, Istanbul
Tel: +90 216 4997081
parker.turkey@parker.com

TW – Taiwan, Taipei
Tel: +886 2 2298 8987

UA – Ukraine, Kiev
Tel: +380 44 494 2731
parker.ukraine@parker.com

UK – United Kingdom, Warwick
Tel: +44 (0)1926 317 878
parker.uk@parker.com

US – USA, Cleveland (industrial)
Tel: +1 216 896 3000

US – USA, Lincolnshire (mobile)
Tel: +1 847 821 1500

VE – Venezuela, Caracas
Tel: +58 212 238 5422

ZA – South Africa, Kempton Park
Tel: +27 (0)11 961 0700
parker.southafrica@parker.com

European Product Information Centre
Free phone: 00 800 27 27 5374
(from AT, BE, CH, CZ, DE, DK, ES, FI, FR, IE, IT, NL, NO, PL, PT, RU, SE, UK, ZA)

